



Servo-assisted 2/2-way diaphragm valve

- Servo-assisted diaphragm with diameter of up to DN 50
- Hard-coupled diaphragm opens without differential pressure
- Vibration-proof, block screwed coil system
- Damped design for quiet closing
- Energy-saving power reduction in all DC versions

Type 0290 can be combined with...



Type 2508

Cable plug



Type 1078

Timer unit
(only for AC version)



Type 2511

ASI cable plug

The 0290 valve is a servo-assisted solenoid valve of the S.EV series. The valve opens without differential pressure. The opening process is supported by the fixed coupling of the diaphragm to the plunger. In the process, the integrated 'soft-kick' function opens in a manner that is gentle on the material. Various diaphragm material combinations are available depending on the application. The housing offered is rounded out by a stainless steel and grey cast iron version. The solenoid coils are moulded with a chemically resistant epoxy. 'Kick and drop' electronics are moulded into all DC variants for reduced electrical power consumption. In combination with a plug in accordance with DIN EN 17301-803 Form A, the valves satisfy protection class IP65 – in combination with a stainless steel housing NEMA 4X.

Circuit function A

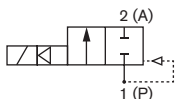

2/2-way valve,
normally closed
by spring force

Technical data	
Orifice	DN 12 - 50 mm
Body material	Brass, stainless steel 1.4581
Coil material	Epoxy
Coil insulation class	H
Internal parts of valve	Brass, stainless steel 1.4105, 1.4301
Seal material	NBR, FKM, EPDM
Media	NBR FKM EPDM
	Neutral media, compressed air, water, hydraulic oil Per-solutions, hot oils Oil and fat-free media, e.g., hot water
Media temperature¹⁾	NBR FKM EPDM
	-10 to +80 °C 0 to +120 °C -30 to +120 °C
Ambient temperature	Max. +55 °C
Voltage tolerance	±10%
Duty cycle	100% continuous cycle
Electrical connection	Cable plug for Ø 7 mm cable, acc. to DIN EN 175301-803 Form A (supplied as standard)
Protection class	IP 65 with cable plug
Installation	As required, preferably with actuator upright

¹⁾ Max. medium temperature for versions with high power electronics (with coding... /UC) withstands 90°.

Technical data, continued

Orifice [mm]	Kv value water P→A [m³/h]	Port connection A/B and P	Pressure range [bar]	Power consumption				Response times		Weight [kg]
				Inrush AC [VA]	UC [W]	Hold AC [VA/W]	UC [W]	Opening [ms]	Closing [ms]	
12	1.8	G 1/2	0 - 16	100	80	25/10	6	100 to 250	700 to 2000	1.0
20	5.0	G 3/4	0 - 16	120	100	32/16	9			1.4
25	10.0	G 1	0 - 16	120	100	32/16	9			1.8
32	16.0	G 1 1/4	0 - 12	120	100	32/16	9	300 to 1000	700 to 4000	2.7
40	16.0	G 1 1/2	0 - 12	120	100	32/16	9			3.1
50	38.0	G 2	0 - 12	-	30	-	30			6.5

Flow rate Kv value water [m³/h]	measured at +20°C, 1 bar pressure at valve inlet and free outlet
Pressure values [bar]	gauge pressures with respect to the prevailing atmospheric pressure
Response times [ms] Opening Closing	measured with water at valve outlet at 6 bar and +20°C pressure build-up 0 to 90% pressure decay 100 to 10%

Material

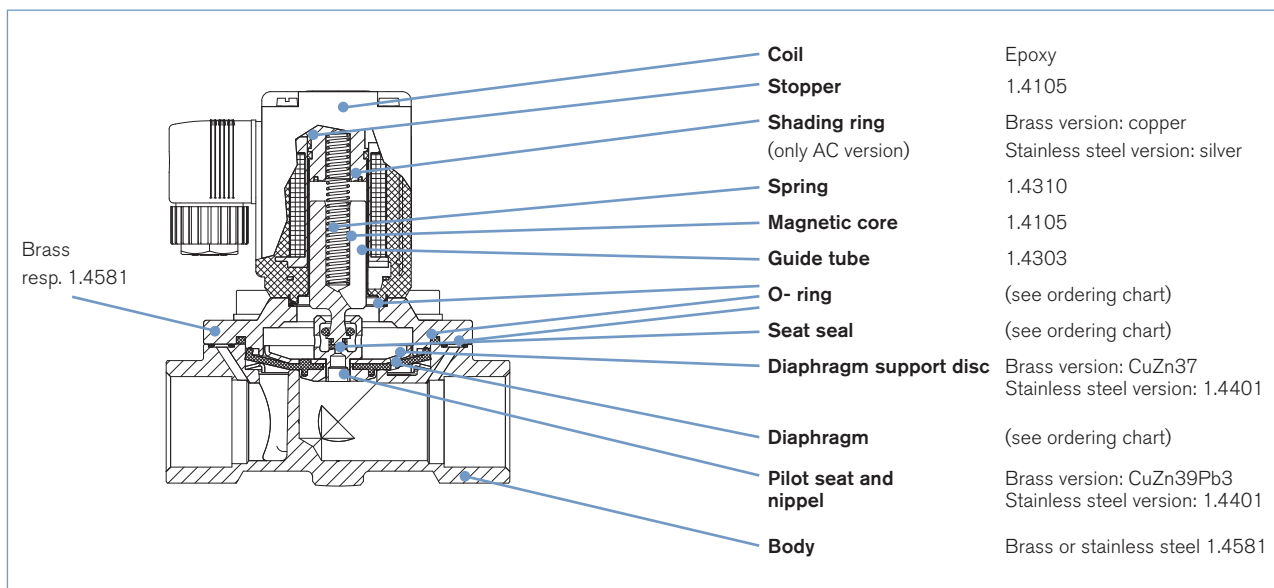

Dimensions [mm]

Threaded port version

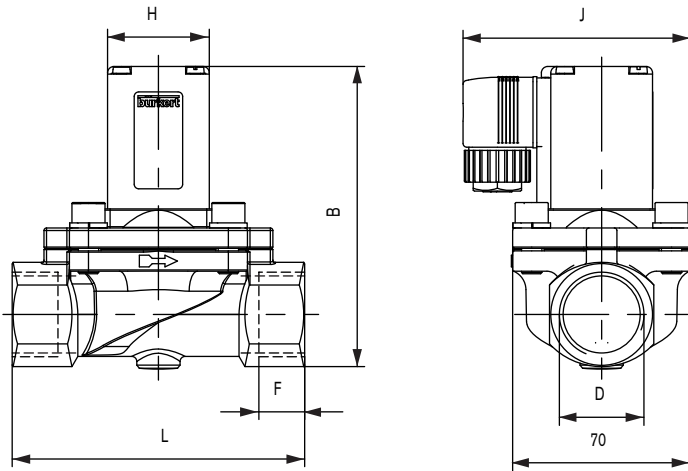

DN	D	B	E	F	H	J	L
12	G 1/2	95.5	40	14	40	73	74.5
20	G 3/4	122	60	16	49	86.5	100
25	G 1	131	70	18	49	91.5	115
32	G 1 1/4	145	85	20	49	99	126
40	G 1 1/2	154	85	22	49	99	126
50	G 2	211	115	24	72	126	164

Flange version acc. to DIN 2501

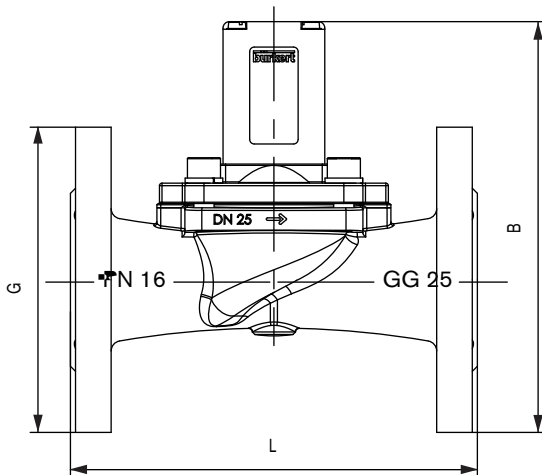

DN	B	G	L
25	175	120	160
32	190	140	180
40	199	150	200
50	259	165	230

Ordering chart for valves (other versions on request)

Brass and stainless steel body, all valves with cable plugs

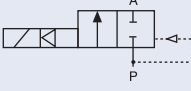
Circuit function	Port connection	Orifice	Kv value water [m ³ /h]	Pressure range [bar]	Diaphragm material	Item no. per voltage/frequency [V/Hz]				
						024/50	024/UC/DC ¹⁾	230/50	110/50	
A 2/2-way valve NC 	Brass body									
	G 1/2	12	1.8	0-16	NBR	043 816	050 294	044 373	049 500	
					FKM	048 707	049 229	042 886	059 240	
					EPDM	045 931	049 050	044 816	049 055	
	G 3/4	20	5.0	0-16	NBR	058 766	049 518	045 292	057 127	
					FKM	053 910	053 674	049 745	067 973	
					EPDM	065 033	058 427	045 290	069 138	
	G 1	25	10.0	0-16	NBR	048 171	053 675	045 293	053 869	
					FKM	–	066 981	058 627	–	
					EPDM	054 245	057 155	045 291	064 887	
	G 1 1/4	32	16.0	0-12	NBR	085 290	085 291	052 513	085 292	
					FKM	–	–	087 203	–	
					EPDM	–	–	085 259	–	
	G 1 1/2	40	16.0	0-12	NBR	085 294	085 295	085 297	085 296	
					FKM	–	–	087 663	–	
					EPDM	–	–	087 732	–	
	G 2	50	38.0	0-12	NBR	–	085 299 ³⁾	085 301 ²⁾	085 300 ²⁾	
					EPDM	–	–	077 494 ²⁾	–	
	Stainless steel body									
	G 1/2	12	1.8	0-16	NBR	043 659	053 595	043 654	052 358	
					FKM	048 708	049 987	042 888	058 407	
					EPDM	045 765	048 606	043 553	049 053	
	G 3/4	20	5.0	0-16	NBR	–	–	065 121	–	
					FKM	065 362	066 381	064 701	066 594	
EPDM					066 460	059 910	065 025	025 870		
G 1	25	10.0	0-16	NBR	–	–	065 414	–		
				FKM	018 121	065 542	066 125	069 477		
				EPDM	–	018 348	059 901	–		

¹⁾ The coil for UC power supply is provided with an integrated high power electronic.
Please check sufficient power supply (see technical data table on page 2)

²⁾ The valve is provided with a cable plug with integrated rectifier

³⁾ Only DC

i Further versions on request

⚡ Voltage
042/50, 110/50, 240/50

🔍 Approvals
UL, UR, CSA

🔌 Port connection
Flange connection acc. to DIN 2501 (DN 25-50)