



2/2-way Angle-Seat Valve with stainless steel design for medium up to +185°C, DN 13-65

- High flow rates
- High cycle life
- Flow optimised body in stainless steel
- Deliverable with flow direction below or above seat
- Clean design for optimal use in hygienic environment
- Suitable for steam up to 10 bar(g)

Type 2100 threaded can be combined with...



Type 8690

Pneum. control unit with feedback

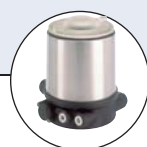

Type 8691

Control head



Type 8695

Control head



Typ 8619

MultiCELL Transmitter/Controller



Typ 8222

Conductivity transmitter

In line with Bürkert's philosophy for modular valves and sensors the construction of the 2100 angle-seat valve fulfils tough criteria for process environments. Unrivalled cycle life and sealing integrity is guaranteed by the proven self adjusting spindle packing with V-seals.

The design enables the easy integration of automation modules whether they are electrical/optical position feedback, pneumatic control units, an integrated fieldbus interface or even an explosion proof feedback.

The fully integrated system has a compact and smooth design, integrated pneumatic lines, IP65/67 protection class and superior chemical resistance.

Technical data	
Orifice	DN 13 to 65
Port connections	
Threaded port acc. to	G 1/2 bis G 2 1/2, NPT 1/2 bis NPT 2 1/2, Rc 1/2 bis Rc 2 1/2
Clamp and welded connections	see seaparate Datasheet
Body material	Casted stainless steel 316L
Actuator material	
Actuator	PPS
Cover	Stainless steel 1.4561 (316Ti)
Sealing material	PTFE
Medium	Water, alcohol, oils, fuels, hydraulic fluids, salt solution, alkali solutions, organic solvents, steam
Viscosity	max. 600 mm ² /s
Spindle packing	PTFE V-rings with spring compensation
Medium temperature	-10 to +185 °C
Ambient temperature	0 bis +55 °C (integrated control head) 0 bis +60 °C (push-in air ports) 0 bis +100 °C (threaded air ports)
Control medium	Neutral gases, air
Max. pilot pressure	max. 10 bar; actuator size 130mm, 7 bar
Pilot air ports	Push-in connector for external ø 6 mm or 1/4" tube, thread G1/8 (on request)
Installation	As required, preferably with actuator in upright position

Content

Valve specifications		System spec. On/Off ELEMENT	Request for quotation
Type 2100		Type 8801-YE	Type 8801-YE
Technical data & ordering info.	p. 1-7	Ordering info. & technical data	p. 13

Technical data angle seat valve Type 2100 flow direction below the seat (for gases and liquids)

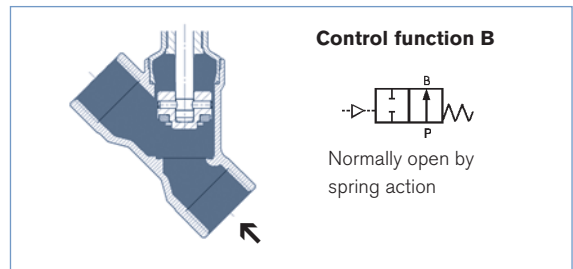
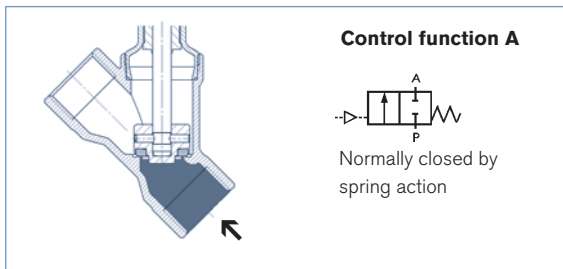

Orifice [mm]	Actuator size [mm]	Kv value water (m³/h)	Minimum pilot pressure SFA [bar]	Operating pressure up to +185°C	
				SFA [bar]	SFB [bar]
13/15	50	5	5.2	25	16
	70	5	5.0	25	16
20	50	10	5.2	16	16
	70	11	5.0	20	16
25	50	15	5.2	9	14.5
	70	18	5.0	16	16
32	70	27	5.0	8.5	16
	90	28	5.0	16	16
40	70	38	5.0	6	16
	90	40	5.0	16	16
50	70	52	-	-	16
	90	55	5.0	10	16
	130	62	5.0	16	16
65	90	85	5.0	5	14
	130	95	5.6	16	16

Flow rate: Kv value water [m³/h]: Measured at +20 °C, 1 bar pressure at valve inlet and free outlet.
Pressure valves [bar]: Overpressure to the atmospheric pressure

Pressure charts with control function B and flow direction below the seat

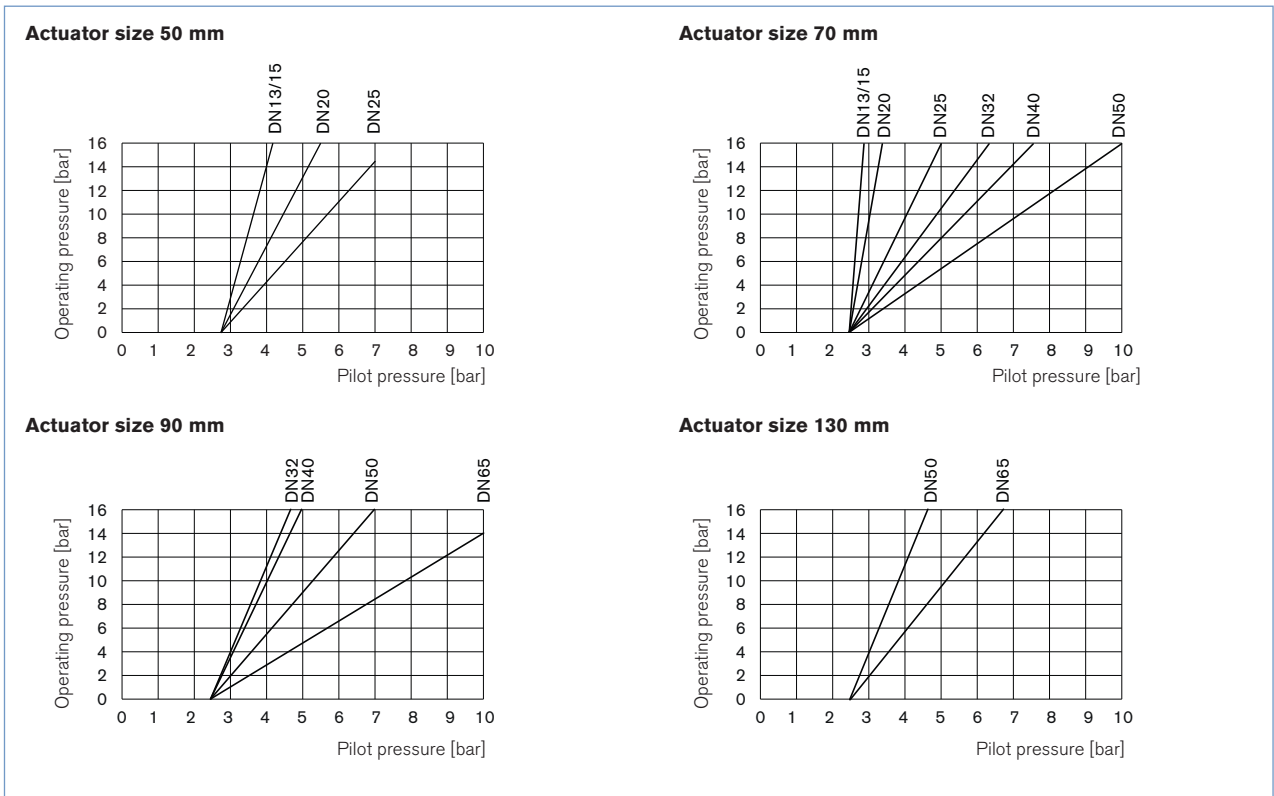

Ordering chart Type 2100, flow direction below the seat (for gases and liquids)

G threaded port, flow direction below the seat

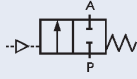
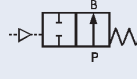
Control function	Orifice [mm]	Actuator size \varnothing [mm]	Port connection threaded port	Minimum pilot pressure [bar]	Operating pressure up to + 185°C [bar]	Item no.
A 2/2-way valve, NC 	13	50	G 1/2	5.2	25	213 619
		70	G 1/2	5.0	25	213 620
	20	50	G 3/4	5.2	16	227 616
		70	G 3/4	5.0	20	213 621
	25	50	G 1	5.2	9	227 617
		70	G 1	5.0	16	213 622
	32	70	G 1 1/4	5.0	8.5	213 623
		90	G 1 1/4	5.0	16	213 624
	40	70	G 1 1/2	5.0	6	213 625
		90	G 1 1/2	5.0	16	213 627
	50	90	G 2	5.0	10	175 108
		130	G 2	5.0	16	188 610
	65	90	G 2 1/2	5.0	5	239 456
		130	G 2 1/2	5.6	16	239 472
B 2/2-way valve, NO 	13	50	G 1/2	see chart on p. 2	16	213 637
		70	G 1/2		16	213 638
	20	50	G 3/4		16	213 639
		70	G 3/4		16	213 640
	25	70	G 1		16	213 641
		32	70		G 1 1/4	16
	40	70	G 1 1/2		16	213 643
		50	70		G 2	16
	65	90	G 2 1/2		14	239 464
		130	G 2 1/2		16	239 479

NPT threaded port, flow direction below the seat

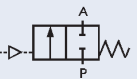
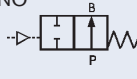
Control function	Orifice (mm)	Actuator size \varnothing [mm]	Port connection threaded port	Minimum pilot pressure [bar]	Operating pressure up to + 185°C [bar]	Item no.
A 2/2-way valve, NC 	13	50	NPT 1/2	5.2	25	213 644
		70	NPT 1/2	5.0	25	213 645
	20	50	NPT 3/4	5.2	16	227 618
		70	NPT 3/4	5.0	20	213 646
	25	50	NPT 1	5.2	9	227 619
		70	NPT 1	5.0	16	213 647
	32	70	NPT 1 1/4	5.0	8.5	213 648
		90	NPT 1 1/4	5.0	16	213 649
	40	70	NPT 1 1/2	5.0	6	213 650
		90	NPT 1 1/2	5.0	16	213 651
	50	90	NPT 2	5.0	10	188 641
		130	NPT 2	5.0	16	188 642
	65	90	NPT 2 1/2	5.0	5	239 457
		130	NPT 2 1/2	5.6	16	239 473
B 2/2-way valve, NO 	13	50	NPT 1/2	see chart on p. 2	16	213 661
		70	NPT 1/2		16	213 662
	20	50	NPT 3/4		16	213 663
		70	NPT 3/4		16	213 664
	25	70	NPT 1		16	213 665
		32	70		NPT 1 1/4	16
	40	70	NPT 1 1/2		16	213 667
		50	70		NPT 2	16
	65	90	NPT 2 1/2		14	239 465
		130	NPT 2 1/2		16	239 480

i Further versions on request

II Control function
I (double-acting)

Ordering chart Type 2100, flow direction below the seat (for gases and liquids), *continued*

RC threaded port, flow direction below the seat

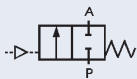
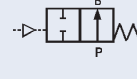
Control function	Orifice (mm)	Actuator size \varnothing [mm]	Port connection threaded port	Minimum pilot pressure [bar]	Operating pressure up to + 185°C [bar]	Item no.
A 2/2-way valve, NC 	13	50	RC 1/2	5.2	25	213 668
		70	RC 1/2	5.0	25	213 669
	20	50	RC 3/4	5.2	16	227 621
		70	RC 3/4	5.0	20	213 670
	25	50	RC 1	5.2	9	227 622
		70	RC 1	5.0	16	213 671
	32	70	RC 1 1/4	5.0	8.5	213 672
		90	RC 1 1/4	5.0	16	213 673
	40	70	RC 1 1/2	5.0	6	213 674
		90	RC 1 1/2	5.0	16	213 675
	50	90	RC 2	5.0	10	188 664
		130	RC 2	5.0	16	188 665
	65	90	RC 2 1/2	5.0	5	239 458
		130	RC 2 1/2	5.6	16	239 474
B 2/2-way valve, NO 	13	50	RC 1/2	see chart on p. 2	16	213 685
		70	RC 1/2		16	213 686
	20	50	RC 3/4		16	213 687
		70	RC 3/4		16	213 688
	25	70	RC 1		16	213 689
	32	70	RC 1 1/4		16	213 690
	40	70	RC 1 1/2		16	213 691
	50	70	RC 2		16	188 679
		90	RC 2 1/2		14	239 466
	65	90	RC 2 1/2		16	239 481
		130	RC 2 1/2		16	239 481

 Further versions on request

 Control function
I (double-acting)

Technical data angle seat valve Type 2100 flow direction above the seat (for gases and steam)

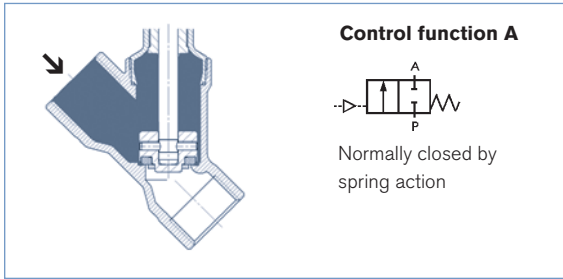

Attention!

Valves with flow above the seat are only conditionally usable for liquid medium. There is a danger of waterhammer!

Orifice [mm]	Actuator size [mm]	Kv value water (m ³ /h)	Operating pressure up to +185°C NC (A) [bar]
13/15	50	5	16
	70	5.1	16
20	50	10	16
	70	12	16
25	50	15	16
	70	19	16
32	70	28	16
40	70	38	16
	90	40	16
50	70	50	12
	90	55	16

Flow rate: Kv value water [m³/h]: Measured at +20 °C, 1 bar pressure at valve inlet and free outlet.
Pressure valves [bar]: Overpressure to the atmospheric pressure

Pressure charts with control function A and flow direction above the seat

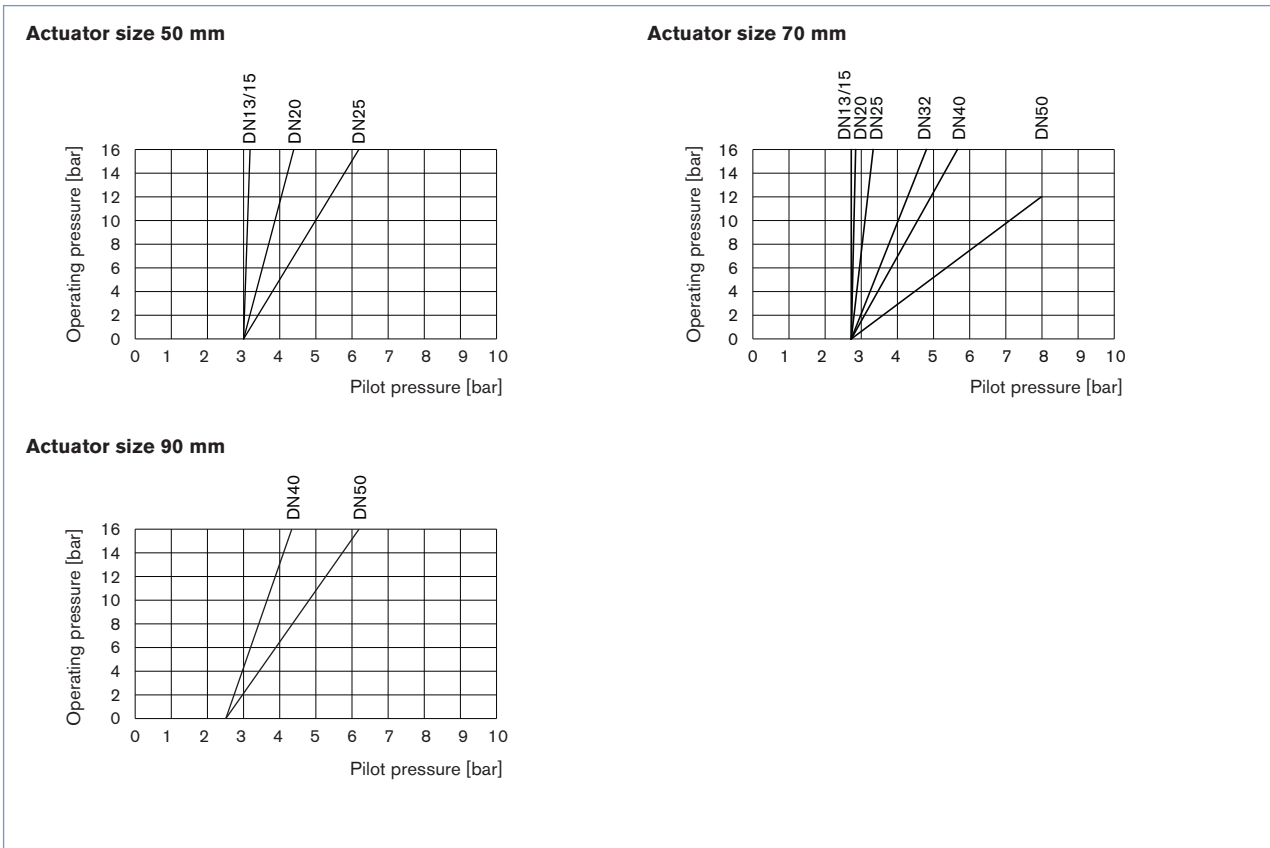

Ordering chart Type 2100 flow direction above the seat (for gases and steam)

G threaded port, flow direction above the seat

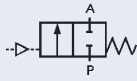
Control function	Orifice (mm)	Actuator size ø [mm]	Port connection threaded port	Minimum pilot pressure [bar]	Operating pressure up to +185°C [bar]	Item no.
A 2/2-way valve, NC 	13	50	G 1/2	see chart on p. 5	16	213 628
		70	G 1/2			213 629
	20	50	G 3/4			213 630
		70	G 3/4			213 631
	25	50	G 1			213 632
		70	G 1			213 633
	32	70	G 1 1/4			213 634
		40	70			G 1 1/2
	50		90			G 1 1/2
		90	70			G 2
	16		175 116			

NPT threaded port, flow direction above the seat

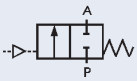
Control function	Orifice (mm)	Actuator size ø [mm]	Port connection threaded port	Minimum pilot pressure [bar]	Operating pressure up to +185°C [bar]	Item no.
A 2/2-way valve, NC 	13	50	NPT 1/2	see chart on p. 5	16	213 652
		70	NPT 1/2			213 653
	20	50	NPT 3/4			213 654
		70	NPT 3/4			213 655
	25	50	NPT 1			213 656
		70	NPT 1			213 657
	32	70	NPT 1 1/4			213 658
		40	70			NPT 1 1/2
	50		70			NPT 2

RC threaded port, flow direction above the seat

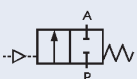
Control function	Orifice (mm)	Actuator size ø [mm]	Port connection threaded port	Minimum pilot pressure [bar]	Operating pressure up to +185°C [bar]	Item no.
A 2/2-way valve, NC 	13	50	RC 1/2	see chart on p. 5	16	213 676
		70	RC 1/2			213 677
	20	50	RC 3/4			213 678
		70	RC 3/4			213 679
	25	50	RC 1			213 680
		70	RC 1			213 681
	32	70	RC 1 1/4			213 682
		40	70			RC 1 1/2
	50		70			RC 2

Materials angle seat valve Type 2100

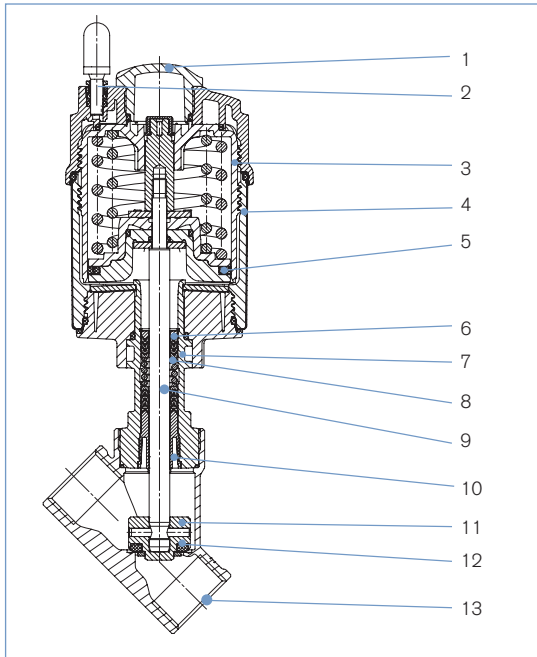

- 1 Optical position indicator** Transparent cap polysulfone PSU
- 2 Pilot air ports** Push-in connector PP (standard)
On request:
Thread G1/8 stainless steel 1.4305
- 3 Actuator** PPS
- 4 Cover** Stainless steel 1.4561 (316Ti)
- 5 Piston seal** FKM
- 6 Spring** Stainless steel 1.4310
- 7 Pipe** Stainless steel 1.4401 (316)/1.4404 (316L)
- 8 Spindle packing** PTFE
- 9 Spindle** Stainless steel 1.4401 (316)/1.4404 (316L)
- 10 Spindle guide** PEEK
- 11 Swivel plate** Stainless steel 1.4401 (316)/(1.4404 (316L)
- 12 Seals** PTFE
- 13 Valve body** Casted stainless steel 316L

Lubricants for spindle packing and actuator are classified according NSF H1

Dimensions angle seat valve Type 2100 [mm]

Threaded body

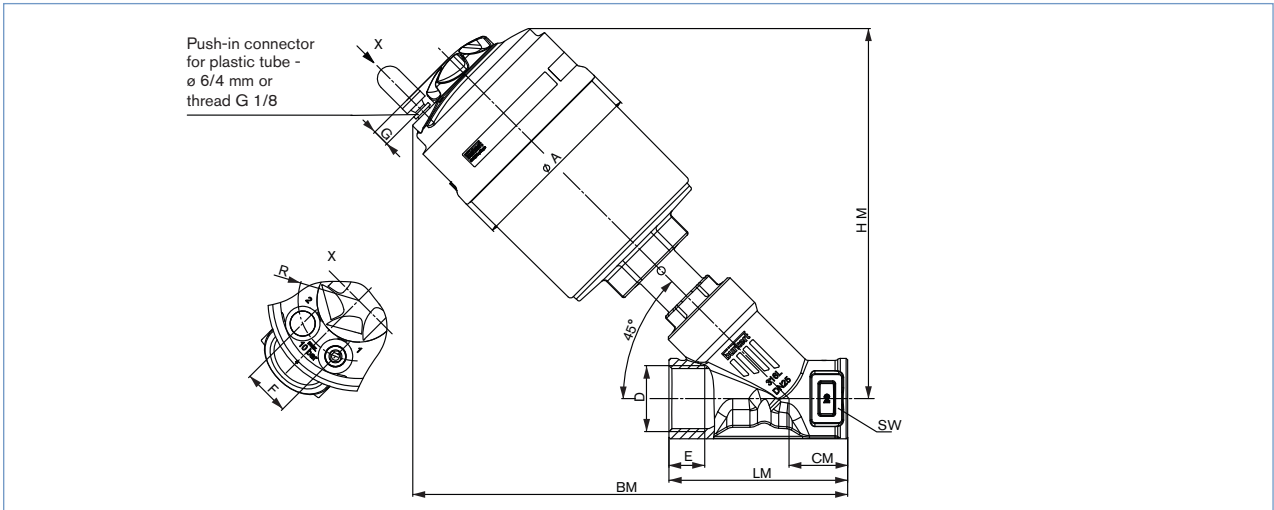

All bodies Orifice [mm]	Actuator size [mm]	All threaded bodies										G		NPT		Rc	
		Ø A	F	G	R	HM	BM	CM	LM	SW	D	E	D	E	D	E	
13	50	64.5	19.8	6.1	17.15	158	185	24	65	27	G 1/2	14	NPT 1/2	13.7	RC 1/2	13.2	
	70	91	23.3	8.5	30.5	173	201										
20	50	64.5	19.8	6.1	17.15	166	195	27	75	34	G 3/4	16	NPT 3/4	14	RC 3/4	14.5	
	70	91	23.3	8.5	30.5	181	211										
25	50	64.5	19.8	6.1	17.15	172	204	29.5	90	41	G 1	18	NPT 1	16.8	RC 1	16.8	
	70	91	23.3	8.5	30.5	195	235										
32	90	120	23.3	8.5	30.5	240	277	36	110	50	G 1 1/4	16	NPT 1 1/4	17.3	RC 1 1/4	19.1	
	70	91	23.3	8.5	30.5	197	236										
	90	120	23.3	8.5	30.5	242	278										
40	90	120	23.3	8.5	30.5	242	278	35	120	55	G 1 1/2	18	NPT 1 1/2	17.3	RC 1 1/2	19.1	
	130	159	23.3	8.5	30.5	293	328										
	70	91	23.3	8.5	30.5	214	262										
50	90	120	23.3	8.5	30.5	255	301	45	150	70	G 2	24	NPT 2	17.6	RC 2	23.4	
	130	159	23.3	8.5	30.5	306	351										
	90	120	23.3	8.5	30.5	270	328										
65	90	120	23.3	8.5	30.5	270	328	57	185	85	G 2 1/2	26	NPT 2 1/2	23.7	RC 2 1/2	26.7	
	130	159	23.3	8.5	30.5	321	378										

Ordering information for valve system On/Off ELEMENT Type 8801-YE

A valve system On/Off ELEMENT Type 8801-YE consists of an angle seat valve Type 2100 and a pneumatic control unit Type 8690, control head Type 8691 (for valve actuator sizes $\varnothing 70/\varnothing 90/\varnothing 130\text{mm}$) or control head Type 8695 (for valve actuator size $\varnothing 50\text{ mm}$) (see separate datasheets).

For the configuration of further valve systems please use the "Request for quotation" on p. 13 [go to page](#)

You order two components and receive a complete assembled and certified valve.

Ordering the valve system On/Off ELEMENT Type 8801-YE with valve actuator sizes $\varnothing 70/\varnothing 90/\varnothing 130\text{mm}$

**Angle seat valve Type 2100 with
actuator sizes $\varnothing 70/\varnothing 90/\varnothing 130\text{ mm}$**

Control units



Pneum- control unit
Type 8690



Control head
Type 8691

**Angle seat valve
with desired control unit**



**Valve system On/Off
ELEMENT Type 8801-YE-K
2100 + 8690**



**Valve system On/Off
ELEMENT Type 8801-YE-H
2100 + 8691**

Click on the orange box "More info." below... you will come to our website for the resp. product where you can download the datasheet.

Pneumatic control unit Type 8690



**More
info.**

The new generation of integrated controllers for combination with actuators from the process valve series Type 21xx is specially designed for the requirements of hygienic process environments. The pneumatic control unit Type 8690 combines electrical position feedback and pneumatic control for single or double-acting actuators, and is also optionally available as an intrinsically safe model to ATEX.

Main customer benefits:

- Compact design of the valve system with integrated controller meets the demands for plant washdown environments through the selection of materials, external seals and integrated control air supply to the actuator.
- Integrated pilot valve with manual actuation
- Air intake filter enhances the process valve system availability
- Simple and reliable actuator adaptations allowing additional actuators of the process valve series, Type 20xx or actuators from other manufacturers to be used

Control head Type 8691



**More
info.**

The new generation of integrated control heads for combination with actuators from the process valve series Type 21xx is specially designed for the requirements of hygienic process environments. The intelligent control head, Type 8691, detects the valve position by means of a contact-free analog position sensor circumventing excessive wear of mechanical parts. Single or double-acting actuators are controlled via the integral pilot valve. Communication interfaces AS-Interface and DeviceNet are available as options.

Main customer benefits:

- Compact, hygienic design of the valve system with integrated controller meets the demands of plant washdown environments through the selection of materials, external seals and integrated control air supply to the actuator.
- Automatic setting of the control head at the push of a button
- Even under dirty or dark environments, a clearly visible status display due to powerful LEDs
- Monitoring and diagnosis: Process valve systems with field bus interface used in modern plant processes
- Integrated pilot valve with manual actuation
- Air intake filter enhances the process valve system availability
- Simple and reliable actuator adaptations allowing additional actuators of the process valve series, Type 20xx or actuators from other manufacturers to be used

Ordering information for valve system On/Off ELEMENT Type 8801-YE, *continued*

A valve system On/Off ELEMENT Type 8801-YE consists of an angle seat valve Type 2100 and a pneumatic control unit Type 8690, control head Type 8691 (for valve actuator sizes $\varnothing 70/\varnothing 90/\varnothing 130\text{mm}$) or control head Type 8695 (for valve actuator size $\varnothing 50\text{mm}$) (see separate datasheets).

For the configuration of further valve systems please use the "Request for quotation" on p. 13 [go to page](#)
You order two components and receive a complete assembled and certified valve.

Ordering the valve system On/Off ELEMENT Type 8801-YE with valve actuator size $\varnothing 50\text{mm}$

Angle seat valve Type 2100 with actuator size $\varnothing 50\text{mm}$



Control unit



Control head
Type 8695

Angle seat valve with desired control unit



Valve system On/Off
ELEMENT Type 8801-YE-M
2100 + 8695

Click on the orange box "More info." below... you will come to our website for the resp. product where you can download the datasheet.

Control head Type 8695



More info.

The new generation of integrated control heads for combination with small actuators from the process valve series Type 21xx is specially designed for the requirements of hygienic process environments. The intelligent control head, Type 8695, detects the valve position by means of a contact-free analog position sensor circumventing excessive wear of mechanical parts. Single and double-acting actuators are controlled via the integral pilot valve. An AS-Interface communication interface is available as an option.

Main customer benefits:

- Compact, hygienic design of the valve system with integrated controller meets the demands of plant washdown environments through the selection of materials, external seals and integrated control air supply to the actuator
- Automatic setting of the control head at the push of a button
- Visual status display on the control head
- Monitoring and diagnosis: Process valve systems with fieldbus interface used in modern plant processes
- Integrated pilot valve
- Simple and reliable actuator adaption

Dimensions for valve system On/Off ELEMENT Type 8801-YE [mm]

Dimensions valve system On/Off ELEMENT Type 8801-YE with pneumatic control unit Type 8690 [mm]

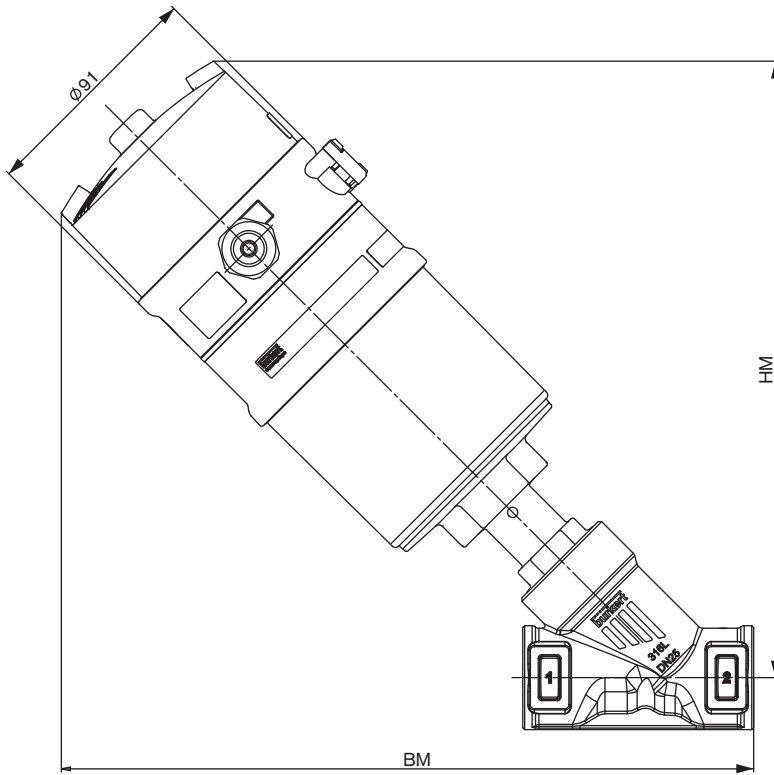

Threaded body

Orifice [mm]	Actuator size [mm]	HM	BM
13	70	227	255
20	70	235	265
25	70	241	274
32	70	249	289
	90	292	329
40	70	251	290
	90	294	330
	130	331	366
50	70	268	316
	90	307	353
	130	344	389
65	90	322	380
	130	359	416

Further dimensions see p. 7

Dimensions for valve system On/Off ELEMENT Type 8801-YE [mm], *continued*

Dimensions valve system On/Off ELEMENT Type 8801-YE with control head Type 8691 [mm]

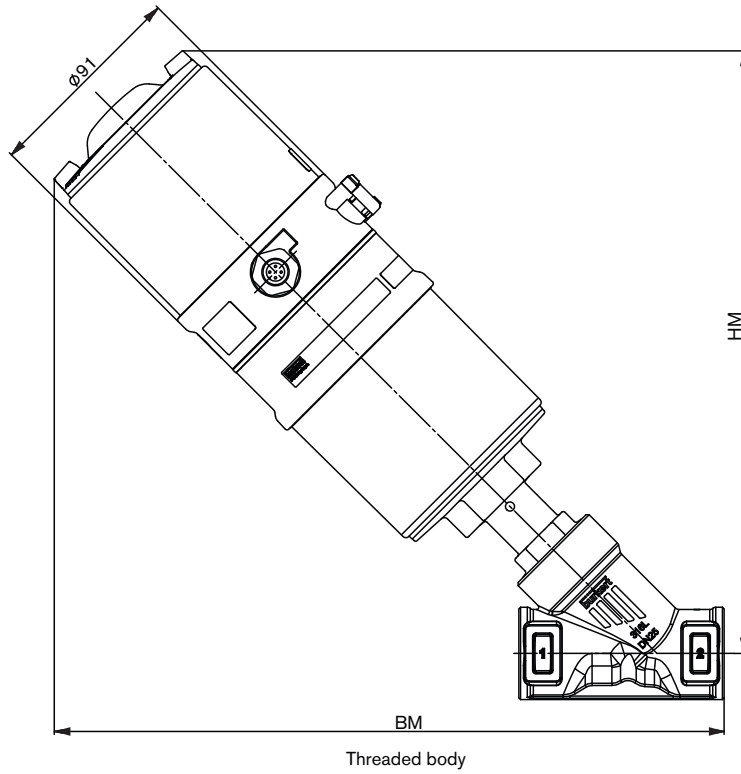

Orifice [mm]	Actuator size [mm]	HM	BM
13	70	251	279
20	70	259	289
25	70	265	298
32	70	273	313
	90	316	353
40	70	275	314
	90	318	354
	130	355	390
50	70	292	340
	90	331	377
	130	368	413
65	90	346	404
	130	383	440

Further dimensions see p. 7

Dimensions for valve system On/Off ELEMENT Type 8801-YE [mm], *continued*

Dimensions valve system On/Off ELEMENT Type 8801-YE with control head Type 8695 [mm]

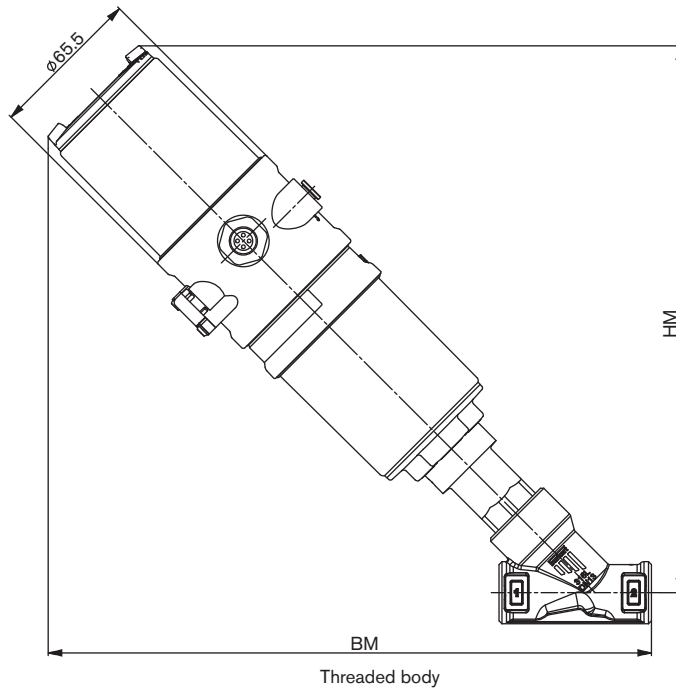

All threaded bodies			
Orifice [mm]	Actuator size [mm]	HM	BM
13	50	234	261
20	50	242	271
25	50	248	280

Valve system On/Off ELEMENT Type 8801-YE - Request for quotation

Note

You can fill out the fields directly in the PDF file before printing out the form.

▶ Please fill out and send to your nearest Bürkert facility* with your inquiry or order

Company	Contact person
Customer no.	Department
Address	Tel./Fax
Postcode/town	E-mail

= mandatory fields to fill out

Quantity

Required delivery date

Operating data

Pipe line DN PN

Pipe material

Process medium

Type of medium Liquid Steam Gas

Valve features

Seal material PTFE NBR Other

Nominal pressure PN

Orifice DN

Type of connection Threaded Welded Clamp

Standard connection ISO DIN Other

Body material selection with welded connection, acc. to EN ISO 1127/ISO 4200 and DIN 11850 St. st. 1.4581 St. st. 316 L



Control function NC¹⁾ NO¹⁾ Double-acting

Pilot pressure min. max.

Please specify item no. if known:

¹⁾ NC: normally closed by spring action; NO: normally open by spring action

Control unit features

For actuator sizes ø70/ø90/ø130 mm		For actuator size ø50 mm
<input type="checkbox"/> Pneumatic Control Unit Type 8690 	<input type="checkbox"/> Control Head Type 8691 	<input type="checkbox"/> Control Head Type 8695 
<p>Pneumatic function</p> <p><input type="checkbox"/> Single-acting <input type="checkbox"/> Double-acting</p> <p><input type="checkbox"/> Without pilot valve</p> <p>Position feedback</p> <p><input type="checkbox"/> 1x inductive <input type="checkbox"/> 2x inductive</p> <p><input type="checkbox"/> 1x inductive (NAMUR) <input type="checkbox"/> 2x inductive (NAMUR)</p> <p><input type="checkbox"/> 1x mechanical <input type="checkbox"/> 2x mechanical</p> <p>Supply voltage</p> <p><input type="checkbox"/> 24 V / DC (ATEX Zone 2/22)</p> <p><input type="checkbox"/> Ex ia IIC T6 (ATEX Zone 1)</p> <p>Pilot air ports</p> <p><input type="checkbox"/> Push-in connector <input type="checkbox"/> Thread G 1/8" external ø 6mm or 1/4"</p> <p>Please specify item no. if known:</p> <p><input type="text"/></p>	<p>Pneumatic function</p> <p><input type="checkbox"/> Single-acting <input type="checkbox"/> Double-acting</p> <p>Pilot air ports</p> <p><input type="checkbox"/> Push-in connector external ø 6mm or 1/4"</p> <p><input type="checkbox"/> Thread G 1/8"</p> <p>Communication</p> <p><input type="checkbox"/> ASI</p> <p><input type="checkbox"/> Multipol M12</p> <p><input type="checkbox"/> Flat cable clip, 1 m cable</p> <p><input type="checkbox"/> DeviceNet</p> <p>Please specify item no. if known:</p> <p><input type="text"/></p>	<p>Pneumatic function</p> <p><input type="checkbox"/> Single-acting <input type="checkbox"/> Double-acting</p> <p><input type="checkbox"/> Push-in connector external ø 6mm or 1/4"</p> <p><input type="checkbox"/> Thread G 1/8"</p> <p>Communication</p> <p><input type="checkbox"/> ASI</p> <p>Please specify item no. if known:</p> <p><input type="text"/></p>

Comments

* To find your nearest Bürkert facility, click on the orange box → www.burkert.com

In case of special application conditions, please consult for advice.

Subject to alteration.
© Christian Bürkert GmbH & Co. KG

1301/10_EU-en_00895001