

High Pressure Filter Pi 420

Operating pressure 400 bar, Nominal size up to 450

1. Features

Efficient filters for modern hydraulic systems

- Modular design
- Minimal pressure loss
- Compact design
- Visual / electrical / electronical differential pressure indication
- Threaded or SAE 4 bolt flange ports

Quality filters, easy to service

- Highly efficient Sm-x filter elements
- β -rated elements per ISO 4572
- Large dirt holding capacity and high differential pressure stability providing optimum element service life
- 100% bubble-point tested elements

Worldwide sales



2. Flow rate/pressure drop curve compl. filter

█ 190 mm²/s (25° E)
█ 33 mm²/s (4.5° E)

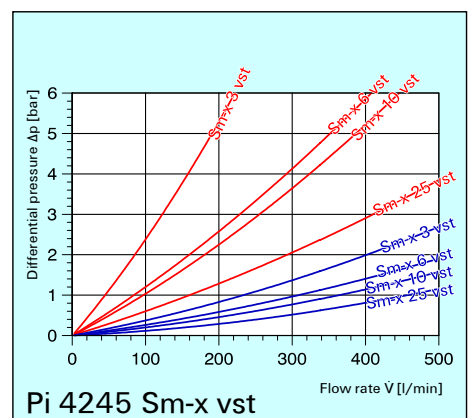
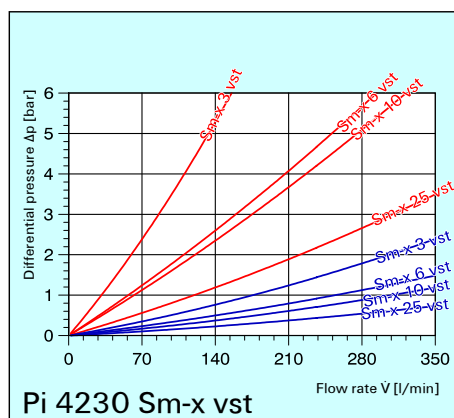
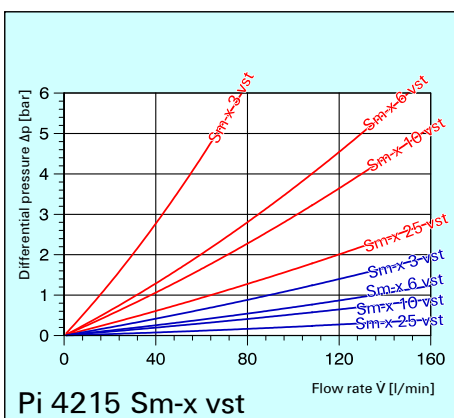
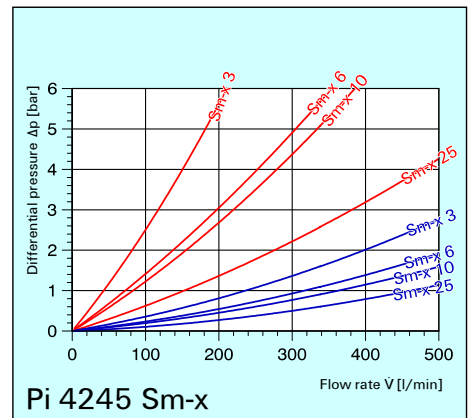
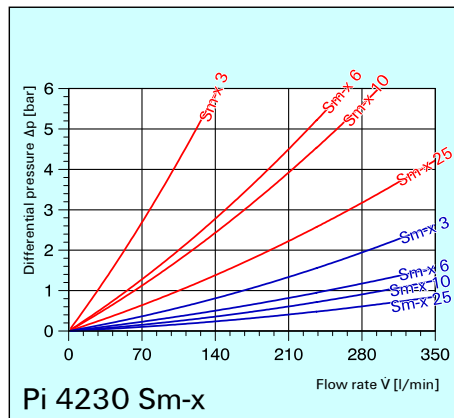
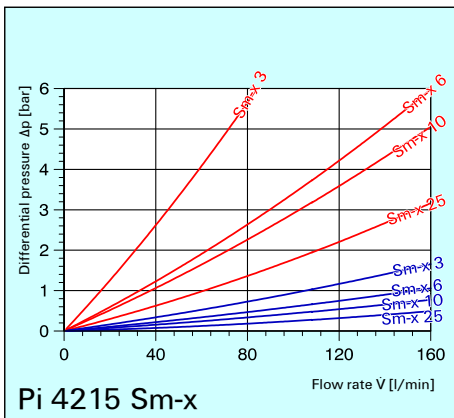
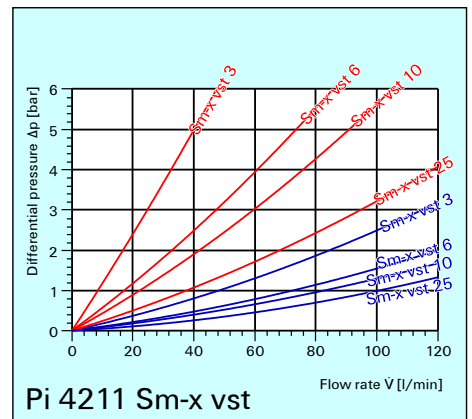
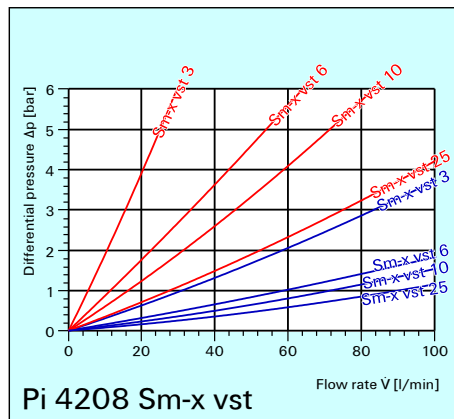
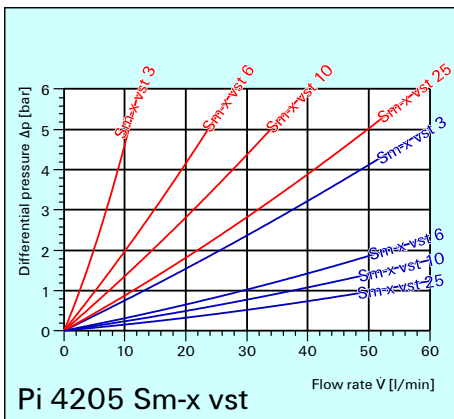
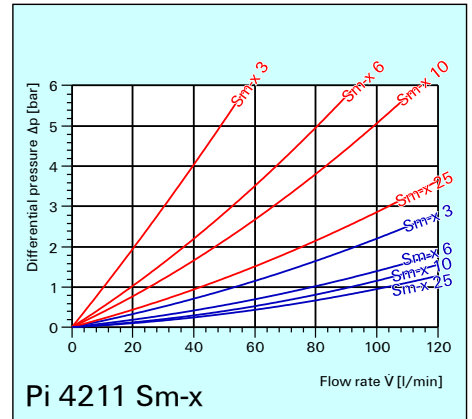
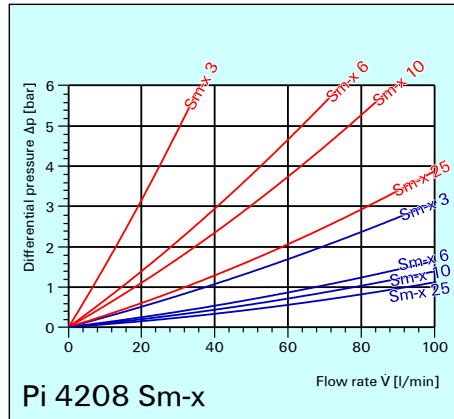
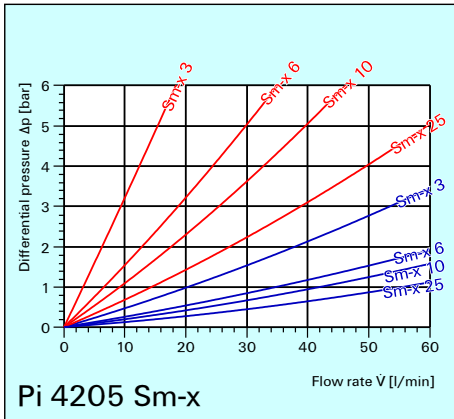

3. Separation characteristics

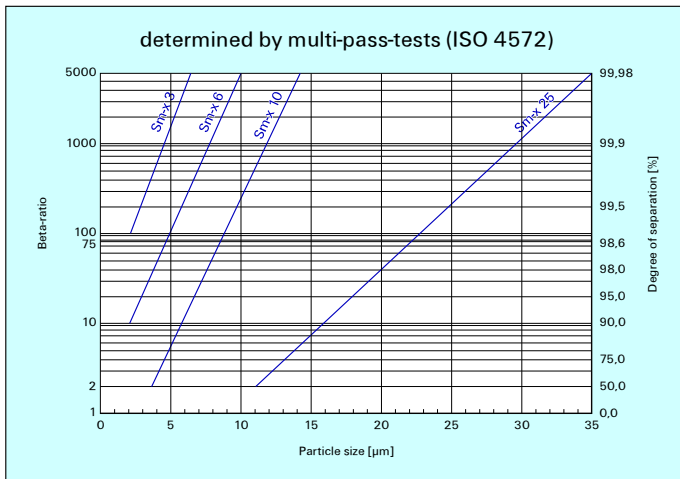

4. Filter performance data

tested according to ISO 4572 (multi-pass-test)

Sm-x-elements
with Δp 20 bar

Sm-x 3 $\beta_3 \geq 75$
 Sm-x 6 $\beta_6 \geq 75$
 Sm-x 10 $\beta_{10} \geq 75$
 Sm-x 25 $\beta_{25} \geq 75$

Sm-x-vst-elements
with Δp 210 bar

Sm-x vst 3 $\beta_3 \geq 75$
 Sm-x vst 6 $\beta_6 \geq 75$
 Sm-x vst 10 $\beta_{10} \geq 75$
 Sm-x vst 25 $\beta_{25} \geq 75$

at 7 bar differential pressure

at 16 bar differential pressure

Example for ordering filters:

- Housing design $\dot{V} = 80$ l/min,
electrical indication
Type-no. Pi 4208-15 Order-no. **766.647.2**
- Filter element Sm-x vst 3
Type-no. Pi 2208 Order-no. **768.020.0**

7. Order numbers

7.1 Housing design

Order number Threaded version	Type number Threaded version	Order number Flanged version	Type number Flanged version	Nominal size (NG)	① with indicator cavity	② with bypass valve	③ with bypass valve and visual indicator	④ with bypass valve and visual / electrical indicator	⑤ with visual indicator	⑥ with visual / electrical indicator
766.635.7	Pi 4205-10	796.771.4	Pi 4205-10 FL	50						
766.636.5	Pi 4205-11	796.772.2	Pi 4205-11 FL							
766.637.3	Pi 4205-12	796.773.0	Pi 4205-12 FL							
766.638.1	Pi 4205-13	796.774.8	Pi 4205-13 FL							
766.639.9	Pi 4205-14	796.775.5	Pi 4205-14 FL							
766.641.5	Pi 4205-15	796.776.3	Pi 4205-15 FL							
766.642.3	Pi 4208-10	796.777.1	Pi 4208-10 FL	80						
766.643.1	Pi 4208-11	796.778.9	Pi 4208-11 FL							
766.644.9	Pi 4208-12	796.779.7	Pi 4208-12 FL							
766.645.6	Pi 4208-13	796.780.5	Pi 4208-13 FL							
766.646.4	Pi 4208-14	796.781.3	Pi 4208-14 FL							
766.647.2	Pi 4208-15	796.782.1	Pi 4208-15 FL							
766.648.0	Pi 4211-10	796.783.9	Pi 4211-10 FL	110						
766.649.8	Pi 4211-11	796.784.7	Pi 4211-11 FL							
766.650.6	Pi 4211-12	796.785.4	Pi 4211-12 FL							
766.651.4	Pi 4211-13	796.786.2	Pi 4211-13 FL							
766.652.2	Pi 4211-14	796.787.0	Pi 4211-14 FL							
766.653.0	Pi 4211-15	796.788.8	Pi 4211-15 FL							
766.654.8	Pi 4215-10	797.859.6	Pi 4215-10 FL	150						
766.655.5	Pi 4215-11	797.860.4	Pi 4215-11 FL							
766.656.3	Pi 4215-12	797.861.2	Pi 4215-12 FL							
766.657.1	Pi 4215-13	797.862.0	Pi 4215-13 FL							
766.658.9	Pi 4215-14	797.863.8	Pi 4215-14 FL							
766.659.7	Pi 4215-15	797.864.6	Pi 4215-15 FL							
766.661.3	Pi 4230-10	797.865.3	Pi 4230-10 FL	300						
766.662.1	Pi 4230-11	797.866.1	Pi 4230-11 FL							
766.663.9	Pi 4230-12	797.867.9	Pi 4230-12 FL							
766.664.7	Pi 4230-13	797.868.7	Pi 4230-13 FL							
766.665.4	Pi 4230-14	797.869.5	Pi 4230-14 FL							
766.666.2	Pi 4230-15	796.450.5	Pi 4230-15 FL							
766.668.8	Pi 4245-10	797.870.3	Pi 4245-10 FL	450						
766.669.6	Pi 4245-11	797.871.1	Pi 4245-11 FL							
766.670.4	Pi 4245-12	797.872.9	Pi 4245-12 FL							
766.671.2	Pi 4245-13	797.873.7	Pi 4245-13 FL							
766.672.0	Pi 4245-14	797.874.5	Pi 4245-14 FL							
766.674.6	Pi 4245-15	797.875.2	Pi 4245-15 FL							

When filter with non bypass configuration is selected, the collapse pressure of the element may not be exceeded

5. Test regulations

MAHLE filter elements are manufactured respectively, tested in accordance with the following international standards:

No.	Designation
ISO 2941	Hydraulic-filter elements: Verification of burst resistance
ISO 2942	Hydraulic-filter elements: Determination of fabrication integrity
ISO 2943	Hydraulic-filter elements: Verification of material compatibility with hydraulic fluids
ISO 3723	Hydraulic-filter elements: Method for testing end-cap load
ISO 3724	Hydraulic-filter elements: Verification of flow fatigue characteristics
ISO 39682	Hydraulic-filters: Evaluation of pressure drop versus flow
ISO 4572	Hydraulic-filter elements: Testing of filter performance (multi-pass-test)

6. Symbols

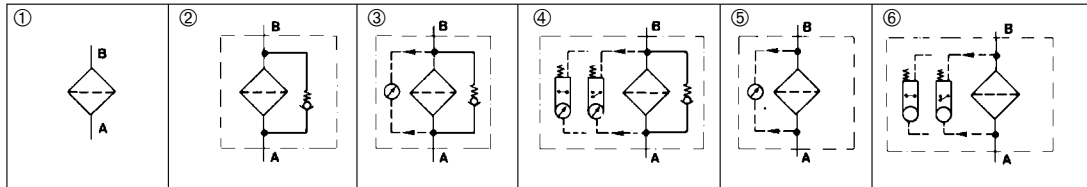

7.2 Filter elements* () = filter surface area [] = type number

Sm-x 3 Δp 20 bar	Sm-x 6 Δp 20 bar	Sm-x 10 Δp 20 bar	Sm-x 25 Δp 20 bar	Sm-x vst 3 Δp 210 bar	Sm-x vst 6 Δp 210 bar	Sm-x vst 10 Δp 210 bar	Sm-x vst 25 Δp 210 bar
(590 cm ²)	(590 cm ²)	(590 cm ²)	(590 cm ²)	(470 cm ²)	(470 cm ²)	(470 cm ²)	(470 cm ²)
				768.019.2	794.353.3	768.038.2	768.050.7
768.013.5	794.350.9	768.032.5	768.044.0				
768.013.5	794.350.9	768.032.5	768.044.0	[Pi 2205]	[Pi 5205]	[Pi 3205]	[Pi 4205]
768.013.5	794.350.9	768.032.5	768.044.0				
[Pi 2105]	[Pi 5105]	[Pi 3105]	[Pi 4105]	768.019.2	794.353.3	768.038.2	768.050.7
				768.019.2	794.353.3	768.038.2	768.050.7
(1150 cm ²)	(1150 cm ²)	(1150 cm ²)	(1150 cm ²)	(900 cm ²)	(900 cm ²)	(900 cm ²)	(900 cm ²)
				768.020.0	794.354.1	768.119.0	768.051.5
768.014.3	794.351.7	768.034.1	768.045.7				
768.014.3	794.351.7	768.034.1	768.045.7	[Pi 2208]	[Pi 5208]	[Pi 3208]	[Pi 4208]
768.014.3	794.351.7	768.034.1	768.045.7				
[Pi 2108]	[Pi 5108]	[Pi 3108]	[Pi 4108]	768.020.0	794.353.3	768.119.0	768.051.5
				768.020.0	794.353.3	768.119.0	768.051.5
(1700 cm ²)	(1700 cm ²)	(1700 cm ²)	(1700 cm ²)	(1315 cm ²)	(1315 cm ²)	(1315 cm ²)	(1315 cm ²)
				768.021.8	794.355.8	768.039.0	768.052.3
768.015.0	794.352.5	768.033.3	768.046.5				
768.015.0	794.352.5	768.033.3	768.046.5	[Pi 2211]	[Pi 5211]	[Pi 3211]	[Pi 4211]
768.015.0	794.352.5	768.033.3	768.046.5				
[Pi 2111]	[Pi 5111]	[Pi 3111]	[Pi 4111]	768.021.8	794.355.8	768.039.0	768.052.3
				768.021.8	794.355.8	768.039.0	768.052.3
(2350 cm ²)	(2350 cm ²)	(2350 cm ²)	(2350 cm ²)	(2010 cm ²)	(2010 cm ²)	(2010 cm ²)	(2010 cm ²)
				768.022.6	795.512.3	768.040.8	768.053.1
768.016.8	795.509.9	768.035.8	768.047.3				
768.016.8	795.509.9	768.035.8	768.047.3	[Pi 2215]	[Pi 5215]	[Pi 3215]	[Pi 4215]
768.016.8	795.509.9	768.035.8	768.047.3				
[Pi 2115]	[Pi 5115]	[Pi 3115]	[Pi 4115]	768.022.6	795.512.3	768.040.8	768.053.1
				768.022.6	795.512.3	768.040.8	768.053.1
(4420 cm ²)	(4420 cm ²)	(4420 cm ²)	(4420 cm ²)	(3800 cm ²)	(3800 cm ²)	(3800 cm ²)	(3800 cm ²)
				768.023.4	795.513.1	768.041.6	768.054.9
768.017.6	795.510.7	768.036.6	768.048.1				
768.017.6	795.510.7	768.036.6	768.048.1	[Pi 2230]	[Pi 5230]	[Pi 3230]	[Pi 4230]
768.017.6	795.510.7	768.036.6	768.048.1				
[Pi 2130]	[Pi 5130]	[Pi 3130]	[Pi 4130]	768.023.4	795.513.1	768.041.6	768.054.9
				768.023.4	795.513.1	768.041.6	768.054.9
(6540 cm ²)	(6540 cm ²)	(6540 cm ²)	(6540 cm ²)	(5600 cm ²)	(5600 cm ²)	(5600 cm ²)	(5600 cm ²)
				768.024.2	794.514.9	768.042.4	768.055.6
768.018.4	795.511.5	768.037.4	768.049.9				
768.018.4	795.511.5	768.037.4	768.049.9	[Pi 2245]	[Pi 5245]	[Pi 3245]	[Pi 4245]
768.018.4	795.511.5	768.037.4	768.049.9				
[Pi 2145]	[Pi 5145]	[Pi 3145]	[Pi 4145]	768.024.2	795.514.9	768.042.4	768.055.6
				768.024.2	795.514.9	768.042.4	768.055.6

*other elements on request

8. Specifications

Design:	line mounting filter
Operating pressure:	400 bar
Static test pressure:	520 bar
Temperature range:	-10 °C to +120 °C (other temperature ranges on request)
Bypass opening pressure:	Δp 7 bar \pm 10 %
Filter head material:	GGG
Filter bowl material:	St
Material of seals:	NBR / PTFE / Cu
Activating pressure of visual / electrical differential pressure indicator:	Δp 5 bar \pm 10 %
Electrical data of contamination indicator:	
Maximum voltage:	230 V \sim / =
Maximum current on contact:	2,5 A
Maximum contact load:	60 VA / 40 W
Inrush current:	70 VA
Type of protection:	IP 65 when inserted and secured
Contact:	bistable
Cable connection:	PG 11 \varnothing 6-10

The electrical indicator function can be changed from the Normally Open position to the Normally Closed position or visa versa by inverting the electrical section.

With the inrush current of 70 VA the indicator can trigger small contactors or contactor relays.

Inductivity in the direct current may require the use of a signal eraser.

For further information and executions please see our leaflet: "Contamination indicators".

Filters compatible with standard mineral oils.

Please contact us in case of using other media.

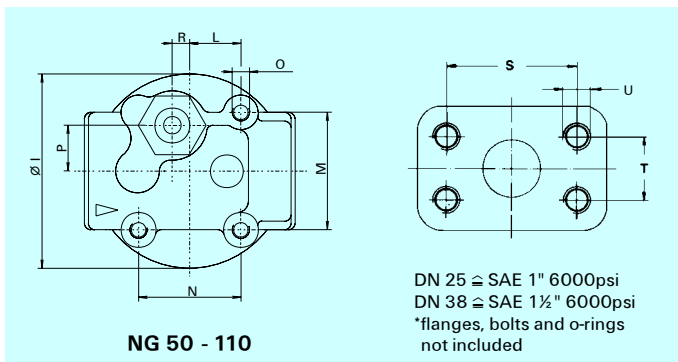

NG 50 - 110

DN 25 \pm SAE 1" 6000psi
 DN 38 \pm SAE 1½" 6000psi
 *flanges, bolts and o-rings
 not included

9. Dimensions

All dimensions (except "C") in mm

Dimension Type	Dimension																			Weight [kg]
	A	B	C	D	E	F	G SW	H	I	K	L	M	N	O	P	R	S	T	U	
Pi 4205	78	31	G ½	189	247	80	27	66	90	92	23,5	54	47	M 8 x 14	21	8	57,1	27,8	M 12 x 20	4,1
Pi 4205 FL		28	DN 25	204	262				85	95	10					-				12
Pi 4208	78	31	G 1	267	325	80	27	66	90	92	23,5	54	47	M 8 x 14	21	8	57,1	27,8	M 12 x 20	4,9
Pi 4208 FL		28	DN 25	282	340				85	95	10					-				12
Pi 4211	78	31	G 1	343	401	80	27	66	90	92	23,5	54	47	M 8 x 14	21	8	57,1	27,8	M 12 x 20	5,8
Pi 4211 FL		28	DN 25	358	416				85	95	10					-				12
Pi 4215	78	46	G 1 ¼	284	342	110	30	109	142	143,5	12	86	-	M 12 x 15	-	23	79,4	36,5	M 16 x 20	12,3
Pi 4215 FL		40	DN 38																	13,3
Pi 4230	78	46	G 1 ¼	409	467	110	30	109	142	143,5	12	86	-	M 12 x 15	-	23	79,4	36,5	M 16 x 20	14,8
Pi 4230 FL		40	DN 38																	15,9
Pi 4245	78	46	G 1 ½	525	583	110	30	109	142	143,5	12	86	-	M 12 x 15	-	23	79,4	36,5	M 16 x 20	17,1
Pi 4245 FL		40	DN 38																	18,6

Pos 1 - Visual contamination indicator

Pos 2 - El. upper section connector
 according DIN 43650
 Execution: Pis 3092, 3105, 3115

Pos 3 - El. upper section connector
 according DIN 43651
 Execution: Pis 3102, 3122, 3110

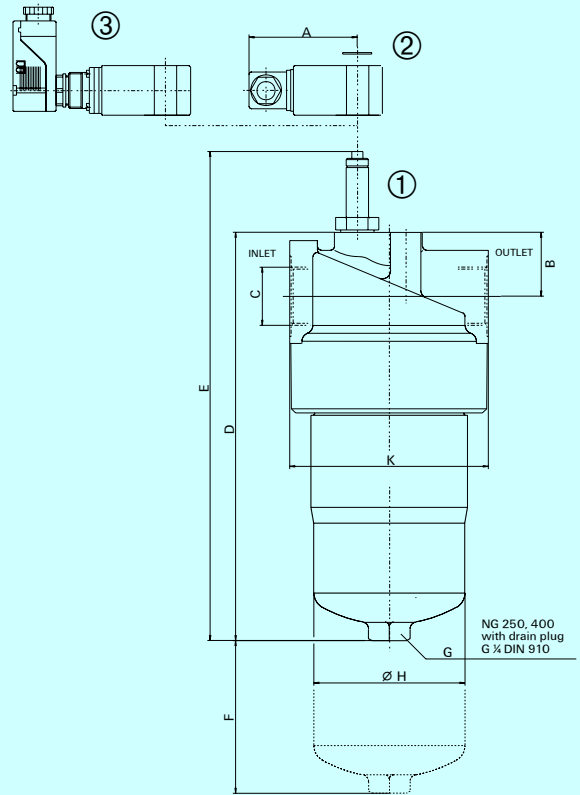

NG 150 - 450

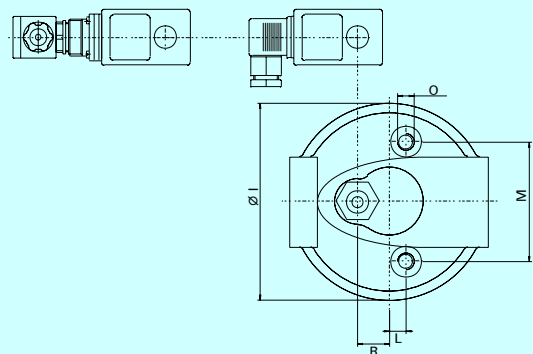

10. Installation, operating and maintenance instructions

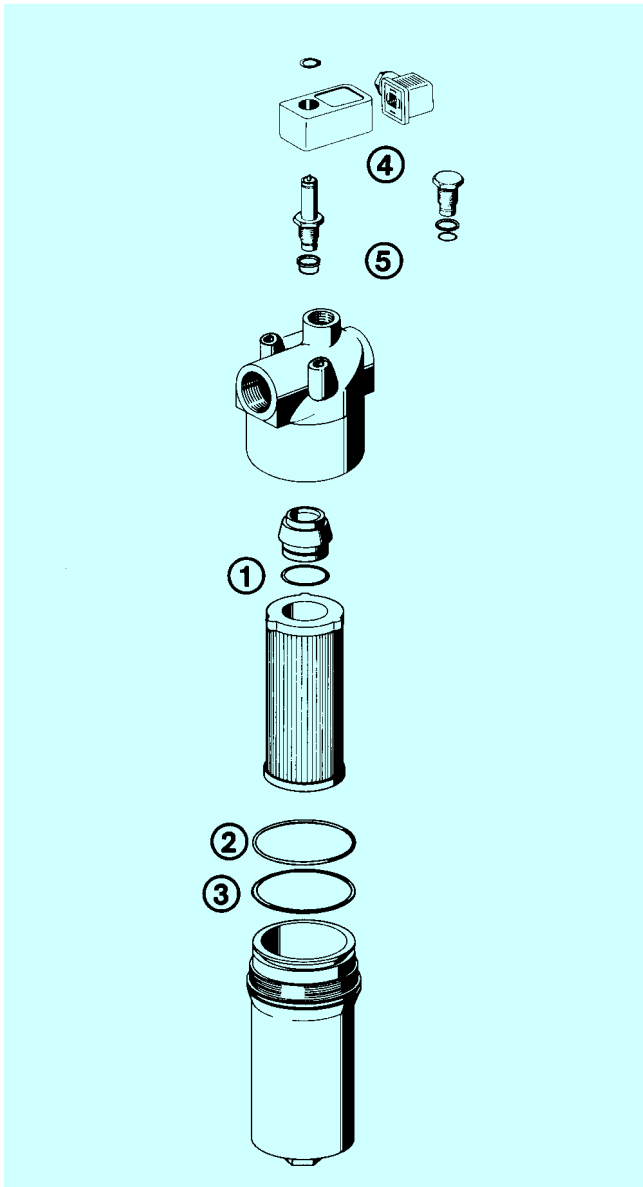

10.1 Filter installation

When installing the filter make sure that sufficient space is available to remove filter element and filter bowl. Preferable the filter should be installed with the filter bowl pointing downwards. The contamination indicator must be visible.

10.2 Connecting the electrical contamination indicator

The electrical indicator is connected via a 2-pole appliance plug according DIN 43650 with poles marked 1 and 2. The electrical section can be inverted to change from Normally Open position to Normally Closed position or vice versa.

10.3 When must the filter element be replaced?

- Filters equipped with visual and electrical contamination indicator:
During cold starts, the indicator may give a warning signal. Depress the red button of the visual indicator once again only after operating temperature has been reached. If the red button immediately pops out again and/or the electrical signal has not switched off after reaching operating temperature, the filter element must be replaced after the end of the shift.
- Filters without contamination indicator:
The filter element should be replaced after the trial run or flushing of the system. Afterwards follow instructions of the manufacturer.
- Please always ensure that you have original MAHLE replacement elements in stock: disposable elements (Sm-x) cannot be cleaned.

10.4 Element replacement

- Stop system and relieve filter from pressure.
- Unscrew the filter bowl by turning counter-clockwise. Clean the bowl using a suitable cleaning solvent.
- Remove filter element with a side-to-side motion.
- Check O-ring and back-up ring on the filter bowl for damage. Replace, if necessary.
- Make sure that the part number on the spare element corresponds with the part number of the filter label. Open the plastic bag and push element over the spigot in the filter head. Now remove plastic bag.
- Complete installation by screwing on the bowl, turning clockwise until it comes to a full stop. Back off the bowl $\frac{1}{8}$ to $\frac{1}{2}$ turn.

11. Spare parts list

Pos.	Part no. /housing		
	Pi 4205–Pi 4211		Pi 4215–Pi 4245
①	Seal kit		Seal kit
-	NBR	754.485.1	NBR 754.488.5
③	FPM	754.486.9	FPM 754.489.3
	EPDM	754.487.7	EPDM 754.490.1
④	Contamination indicator		
	visual	visual/electrical	electrical upper part only
	766.991.4	766.986.4	753.655.0
	Pis 3093/5	Pis 3092/5	
⑤	Seal kit for contamination indicator		
	NBR	776.027.5	
	FPM	776.028.3	
	EPDM	776.029.1	

Subject to technical alteration without prior notice.