



# Technical Data Sheet Type 46



2/2-way solenoid valve  
 NC - Valve normally closed (as standard)  
 NO - Valve normally open (as option)

Pilot operated piston design valve. The mentioned minimum pressure difference between inlet and outlet is necessary for proper operation. In standard (NC) the valve closes with spring power.

■ Solenoid valve for high pressure applications

Type 46

## TECHNICAL SPECIFICATIONS

Type of control	Pilot operated, no pressure difference required
Design	Piston design
Connection	Threaded G1/4 - G1/2 DIN ISO 228/1 (BSP) <small>Further connections like NPT on request</small>
Installation	Preferable with actuator upright
Pressure	1 - 100 bar (see table on page 2)
Medium	Clean, neutral, gaseous and liquid media
Viscosity	22 mm <sup>2</sup> /s
Temperature range	Medium: -40 °C up to +80 °C Ambient: -40 °C up to +50 °C <small>In consideration of the restrictions described on page 4</small>
Body material	Stainless steel 1.4581
Metallic inner parts	Stainless steel
Sealing	PTFE
Supply voltage	AC~ 24V, 110V, 230V DC= 12V, 24V <small>Other supply voltages on request</small>
Voltage tolerance	-10% / +10%
Power consumption	.012 = 18 Watt    .148 = 10 Watt ⚠ .802 = 24 Watt    .808 = 24 Watt ⚠
Protection class	IP65 acc. to DIN 60529
Duty factor	100% ED-VDE 0580
Connection type	Plug
Ex-proof	acc. to 2014/34/EU (ATEX) <small>Further Ex-proof on request</small>

## VALVE FEATURES

- For high pressure applications up to 100 bar
- Pressure difference is required
- High life time
- Simple compact valve design
- High-quality materials
- Reliable and sturdy sealing elements

## FUNCTION

NC – non energized closed      NO – non-energized open

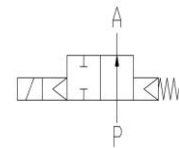
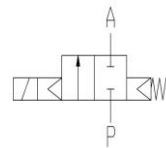

## CERTIFICATES



## ORDERING SYSTEM

Type	Conn.	Housing	Seal	Coil	Option
. 4 6	2 3	/ 0 8	0 4	/ . 8 0 2	- N O
	21 G 1/4 22 G 3/8 23 G 1/2	08 St. steel 1.4581	04 PTFE	2 Standard IP65 8 Explosion proof acc. to directive 2014/34/EU (ATEX)	

# TECHNICAL FEATURES

G	Seat Ø mm	Kv-value m³/h	Standard type	max. pressure for coils			max. pressure for coils ATEX		
				.012	.802	.802-NO	.148	.808	.808-NO
1/4	8,0	1,0	.4621/0804/	5-80	1-100	1-70	5-60	1-100	1-70
3/8	8,0	1,2	.4622/0804/	5-80	1-100	1-70	5-60	1-100	1-70
1/2	8,0	2,0	.4623/0804/	5-80	1-100	1-70	5-60	1-100	1-70

# DIMENSIONS

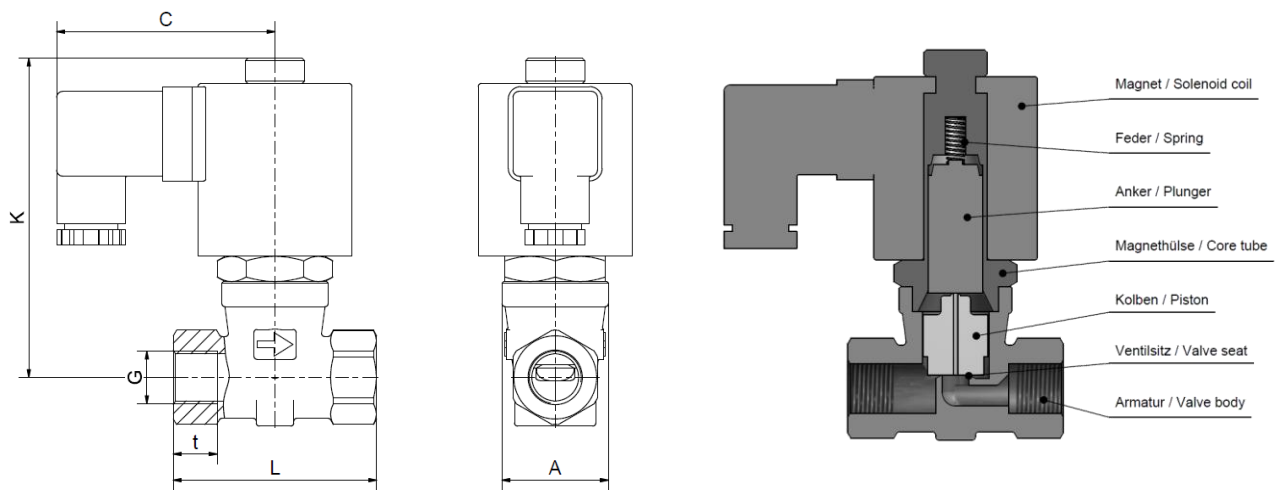

Coil	.012 / .148*			.802 / .808*		
Type	4621	4622	4623	4621	4622	4623
G	1/4	3/8	1/2	1/4	3/8	1/2
A	34	34	34	34	34	34
C	61	61	61	70	70	70
K	91	91	91	102	102	102
L	65	65	65	65	65	65
t	14	14	14	14	14	14
kg	0,7	0,65	0,6	1,2	1,15	1,1

\*Differing dimension "C" for ATEX-coils

## INFORMATION

- It is imperative to observe the installation and safety instructions in our operating and service manuals.
- For information on our GSR ordering code, please refer to our catalogs. If you have any questions, we will be glad to assist you.
- Required ordering information: valve type, function NC/NO, pressure range, connection, nominal width, medium, flow rate, medium and ambient temperatures, connection voltage.
- **Detailed production-specific drawings and other technical information will be made available when an order is placed**

## PLEASE NOTE

Each individual application decides which valve type is required, the main factor being the resistance of the materials to the operating medium. The correct selection of materials requires knowledge of the concentration, temperature and degree of contamination of the medium. Other criteria include the operating pressure and max. volumetric flow, since, in addition to high temperatures, high pressures and high flow rates must also be taken into account when selecting the materials.

**All materials used for our valves, be it housing, seals or magnets, will be carefully selected in view of the different application areas. Any information given is non-binding and serves for orientation only. No claims under warranty can be derived therefrom.**

## Heating and power of solenoid coils

The GSR default solenoid valves are designed for continuous operation (100% ED = power-on time) under normal operating conditions. The pulling force of a solenoid coil is basically influenced by three elements:

- The self-heating of the magnetic coil
- The medium temperature
- The ambient temperature

GSR solenoid coils are by default designed for a maximum ambient temperature of +35 °C. This specification applies for the maximum allowable operating pressure specified in the data sheet of the corresponding valve, 100% duty cycle and a medium temperature of +80 °C.

A higher ambient temperature is possible, when lower values are applied for the other influencing parameters. When the max. operation pressure and max. ambient temperature of +50 °C is given the medium temperature is not allowed to be higher than max. +50 °C. In addition to that, deviations from the default design temperature range are possible, e.g. when temperature coils or other constructive measures are used. Please contact the GSR headquarters to discuss the specific application.

More precise specifications and technical data with regard to the operating conditions can be found in the data sheets of the solenoid coils and the solenoid valve regarded. Please observe that the surface temperature of a permanently loaded coil can amount up to +120 °C, solely by the self-heating of the coil. The power consumption of our default solenoid valves was calculated to DIN VDE 05820 for a coil temperature of +20 °C.

- The GSR logo is a registered trademark of GSR Ventiltechnik GmbH & Co. KG.
- Note: All texts and images are the property of GSR Ventiltechnik GmbH & Co. KG and must not be replicated or modified, not even in part, without written approval.
- Original products may differ from the product images shown, due to different materials and the like.
- Subject to error and changes.

**Stand: 02.18, MK-MG, Version 1.**