

DIFFERENTIAL PRESSURE TRANSMITTER TYPE PD39X

In applications where the differential pressure is more than 5% of the maximum standard pressure range, differential pressure measurement with two absolute pressure sensors offers major advantages over conventional methods of differential pressure measurement (such as the Series PD-10).

The Series PD-39 X does not measure the differential pressure directly - instead, it uses two absolute pressure sensors to take the measurement indirectly. As well as reducing costs, this differential pressure transmitter is also more robust in relation to unbalanced (one-sided) overloading. The differential pressure range should be at least 5% of the standard pressure range. Each pressure side has two pressure connections, so the PD-39 X is easy to use in pressure lines.

So that the differential pressure can also be measured exactly if the standard pressure range/differential pressure ratio is high, this series also features the tried-and-tested microprocessor-based technology that is used in Series 30 X. All reproducible pressure sensor errors (i.e. non-linearities and temperature dependencies) are entirely eliminated thanks to mathematical error compensation. The sensor signals are measured with a 16-bit A/D converter, so the individual standard pressure ranges can be measured to an accuracy of 0,05%FS throughout the entire pressure and temperature range.

Digital Interface

The transmitters have a bus-compatible two-wire RS485 half-duplex interface which is modelled on the "MODBUS RTU". KELLER offers interface converters to RS232 or USB for use here. The READ30/PROG30 program and the protocol are freely available. The interface offers these capabilities:

- Readout of pressure and temperature values for both sensors. This allows readout of the differential pressure as well as the two standard pressure ranges.
- Calibration of zero points and amplification.
- Scaling of the analog output to different pressure ranges or units.
- Configuration settings such as measurement rate, low-pass (LP) filter, bus address, etc.
- Readout of information such as serial number, compensated pressure and temperature ranges, etc

Analog Output

The analog output is freely scalable via the interface. For flow measurements, the root of the differential pressure can also be outputted. The calculated value can be outputted via an analog interface (0...10 V or 4...20 mA).



Low pressure type



Medium pressure type

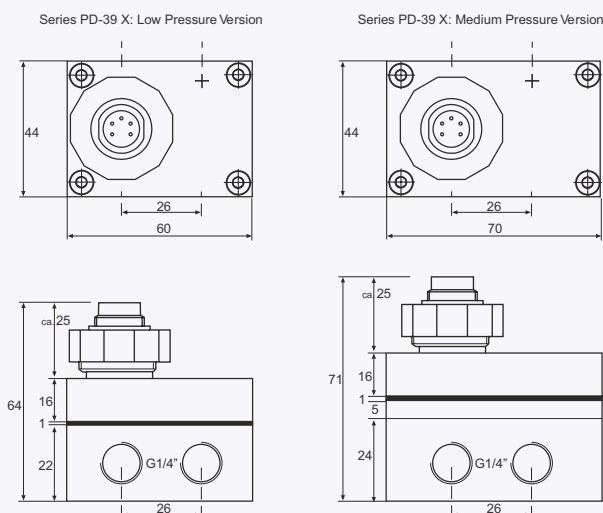

PIN ASSIGNMENT

Output	Function	Binder 723	DIN 43650	MIL C-264882
4...20mA	OUT/GND	1	1	C
2-Wire	+Vcc	3	3	A
0...10V	GND	1	1	C
3-Wire	OUT	2	2	B
	+Vcc	3	3	A
Program-	RS485A	4		D
ming	RS485B	5		F



DIFFERENTIAL PRESSURE TRANSMITTER TYPE PD39X

SPECIFICATIONS

Pressure Ranges (FS) and Overpressure in Bar

Version	Series 39 X Low Pressure			Series 39 X Medium Pressure	
	3	10	25	100	300
Standard Pressure Ranges *					
Overpressure	10	20	30	200	450

Differential Pressure Ranges All ranges are scalable within standard pressure range.
Error band calculation for differential pressure see box

* max. measurable pressure per pressure connection

Storage-/Operating Temperature	-40...100 °C
Compensated Standard Range	-10...80 °C
Error Band ⁽¹⁾⁽²⁾	≤ 0,05 %FS typ. ≤ 0,1 %FS max.
True Output Rate	200 Hz
Resolution ⁽²⁾	≤ 0,002 %
Long Term Stability typ. ⁽²⁾	0,1 %

⁽¹⁾ Linearity + Hysteresis + Repeatability + Temperature Error

⁽²⁾ Accuracy and Resolution referred to Standard Pressure Range

Output Signal	4...20 mA, 2-wire	0...10 V, 3-wire
Supply (U)	8...28 Vcc	13...28 Vcc
Load Resistance	(U-7V)/0,02 A	>5'000 Ω
Electrical Connection	- Binder-plug 723 (5 pole) - DIN 43650 plug - MIL C-26482 plug (6 pole)	
Programming	RS485 half-duplex	
Insulation	10 MΩ / 50 V	

Pressure Endurance °C	10 Mio. Pressure Cycles 0...100 %FS at 25 °C
Vibration Endurance	20g, 20 to 5'000 Hz
Shock Endurance	20 g sinus 11 msec.
Protection	IP65
CE-Conformity	EN 61000-6-1 to -4 (with screened cable)
Material in Contact with Media	Stainless Steel 316L (DIN 1.4435) O-ring: Nitrile or Viton®
Dead Volume Change	< 0,1 mm ³
Pressure Ports	G1/4 female (2 per pressure side)
Weight	Series 39 X Low Pressure: ≈ 475 g Series 39 X Medium Pressure: ≈ 750 g

Options

- Versions for hazardous areas / Other pressure ranges / Supply 32 V / Electrical cable output / Oil Filling: Fluorized Oil (O2-compatible), Olive Oil, Low Temperature Oil / Other connections



Double sensor with electronic circuit.
In this state, the sensors are mounted in test fixtures and tested in furnaces in lots of 100, subsequently mounted in the Series 39 X Low Pressure housings.

Error Band Differential Pressure Range

The error band of the differential pressure (in % of the differential pressure measuring range) is calculated as follows:

Error band of the differential pressure range =

$$\text{Max. Error Band of Stand. Press. Range} \times \frac{\text{Standard Press. Range}}{\text{Diff. Pressure Range}}$$

Example: Standard Pressure = 10 bar
Differential Pressure = 4 bar.
Error Band (in %FS) of the diff. pressure = 0,1 x 10/4 = 0,25%

Polynomial Compensation

This uses a mathematical model to derive the precise pressure value (P) from the signals measured by the pressure sensor (S) and the temperature sensor (T). The microprocessor in the transmitter calculates P using the following polynomial:

$$P(S,T) = A(T) \cdot S^0 + B(T) \cdot S^1 + C(T) \cdot S^2 + D(T) \cdot S^3$$

With the following coefficients A(T)...D(T) depending on the temperature:

$$\begin{aligned} A(T) &= A_0 + A_1 \cdot T + A_2 \cdot T^2 + A_3 \cdot T^3 \\ B(T) &= B_0 + B_1 \cdot T + B_2 \cdot T^2 + B_3 \cdot T^3 \\ C(T) &= C_0 + C_1 \cdot T + C_2 \cdot T^2 + C_3 \cdot T^3 \\ D(T) &= D_0 + D_1 \cdot T + D_2 \cdot T^2 + D_3 \cdot T^3 \end{aligned}$$

The transmitter is factory-tested at various levels of pressure and temperature. The corresponding measured values of S, together with the exact pressure and temperature values, allow the coefficients A₀...D₃ to be calculated. These are written into the EEPROM of the microprocessor.

When the pressure transmitter is in service, the microprocessor measures the signals (S) and (T), calculates the coefficients according to the temperature and produces the exact pressure value by solving the P(S,T) equation.

Calculations and conversions are performed at least 200 times per second depending on the format of the signals.

The resolution is 0,002% of the standard pressure.