

Electromotive 2 way diaphragm on/off valve



- Safety position with energy pack
- Fast shut off
- Adjustable force for increased diaphragm lifetime
- Various diaphragms, stainless steel and plastic bodies available
- Diagnostic functions and fieldbus integration

Options



Rugged Display

With operating buttons

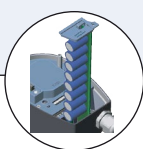

SAFEPOS

Energy-pack



Type 3361

Globe control valve



Fieldbus

The innovative diaphragm on/off valve Type 3323 is the solution when it comes to on/off control in areas with media contact such as the Food and Beverage, Cosmetic, Pharma and Biopharma Industry. The electromotive actuator with ball screw shuts the diaphragm valve quasi delay free with – for electromotive valves – unique speed of 4 mm/s within 1.5...4.5 seconds. If necessary, the safety position can be realized with optional energy storage in case of power failure. Pressure variations or shocks in the medium aren't transferred to the valve position. Many helpful functions for process monitoring, valve diagnostics and predictive maintenance can be used. Beside the mechanical position indication a 360°-LED illuminated ring displays valve position and information about warnings or errors. Various communication standards up to modern fieldbus systems are available. Trusted valve bodies and diaphragms ensure media separation with minimum dead leg and are easy to clean. Demanding environments are no problem for Type 3323 with its high IP-protection and high resistance to vibration and shocks. Hygienic design allows a fast and residue-free exterior cleaning. The actuator force can be exactly adjusted for the operating conditions to optimize diaphragm life.

Technical data

Port connection size	DN8...DN50 (¼"...2")
Diaphragm size	8...40
Body material	
Stainless steel	forged 316L/1.4435/BN2 tube 316L/1.4435/BN2 cast, tank bottom and T-body on request
Plastic	PVC (Polyvinyl chloride) PP (Polypropylene) PVDF (Polyvinylidene fluoride)
Port connections stainless steel	
Weld ends	ASME BPE / DIN 11866 C DIN EN ISO 1127/ISO 4200/DIN11866 B DIN 11850 2/DIN11866 A BS4825 SMS 3008 DIN 11850 0
Clamps	ASME BPE DIN 32676 A (with pipe DIN 11850 2) DIN 32676 B (with pipe ISO 4200) further port connections on request
Port connections plastic	True union (solvent), true union (weld), weld ends and solvent sockets
Surface finish - forged	
internally electropolished	Ra ≤ 0.38 µm (ASME BPE SF4)
internally mechanically polished	Ra ≤ 0.5 µm (ASME BPE SF1)
Surface finish - tube body	
internally electropolished	Ra ≤ 0.38 µm (ASME BPE SF4)
Materials	
Diaphragm materials	EPDM (AD), PTFE/EPDM (EA), advanced PTFE/EPDM (EU), Gylon®/EPDM laminated (ER), FKM (FF)

Content

Technical data/dimensions

forged body	p. 11	tube body	p. 14	plastic body	p. 16
-------------	-------	-----------	-------	--------------	-------

Technical data, continued

Medium temperature EPDM (AD) PTFE/EPDM (EA) PTFE/EPDM (EU) GYLON®/EPDM laminated (ER) FKM (FF)	-10 to +143 °C (steam sterilisation +150 °C for 60 min) -10 to +130 °C (steam sterilisation +140 °C for 60 min) -5 to +143 °C (steam sterilisation +150 °C for 60 min) -5 to +130 °C (steam sterilisation +140 °C for 60 min) 0 to +130 °C (not recommended for steam)
Media	Neutral gases and liquids, high-purity, sterile, aggressive or abrasive fluids
Viscosity	Up to viscous
Installation	As required, preferably with actuator in upright position
Ambient temperature	-10 to +65 °C* (without SAFEPOS energy storage) -10 to +55 °C* (with SAFEPOS energy storage) * depends on media temperature see temperature chart
Safety position at power failure	with SAFEPOS energy-pack: opened, closed or free programmable without SAFEPOS energy-pack: blocked in last position
Power supply	24 V DC ± 10 % (max. residual ripple 10 %)
Closure time	< 1.5 sec... to 4.5 sec... depending on diaphragm size
Travel speed	4 mm/s
Duty cycle	100 %
Protection class	IP65 / IP67
Binary control	0...5 V (log. 0) 10...30 V (log.1)
Vibration, sinusoidal	5 g according to IEC 60068-2-6 Test Fc
Shock, mechanical	50 g according to IEC 60068-2-27 Test Ea
Digital control (fieldbus)	EtherNet/IP, Modbus/TCP, PROFINET (optional)
Approval and Conformity	ATEX II Cat 3G/D / IECEx (optional) cULus Cert. No. 238179 (optional)
Ignition protection	II 3G Ex ec IIC T4 Gc II 3D Ex tc IIIC T135°C Dc

Structure and function

The electromotive linear actuator consists of a brushless direct current motor, gears and a threaded spindle. The valve spindle, which is connected to the threaded spindle, transfers the force to the diaphragm. The electronic control system is actuated either via a standard signal (digital) or via a fieldbus (digital). Optionally there is the energy pack (SAFEPOS energy-pack) for the device. If the supply voltage fails, the energy pack supplies the actuator with the required energy to move the valves into the required position which can be adjusted via a menu.

The valve position can be manually changed in 2 ways. Either over an electrical manual control or over mechanical manual control, if no supply voltage applied.

The device can be set and operated either via 2 capacitive buttons and 4 DIP switches. There is also the option of setting the device via the bus Service interface and by using the PC software "Bürkert-Communicator".

The intelligent process valve Type 3323 offers options for process monitoring, valve diagnostics and predictive maintenance. The state of the device is monitored and if necessary warnings or error messages for inadmissible environmental and operational conditions, disfunctional components or a critical state of the energy storage are displayed.

For a good diaphragm lifetime the actuator force is adjusted according to diaphragm size by default. It can even be adapted according to the operational conditions for an optimum diaphragm cycle life.

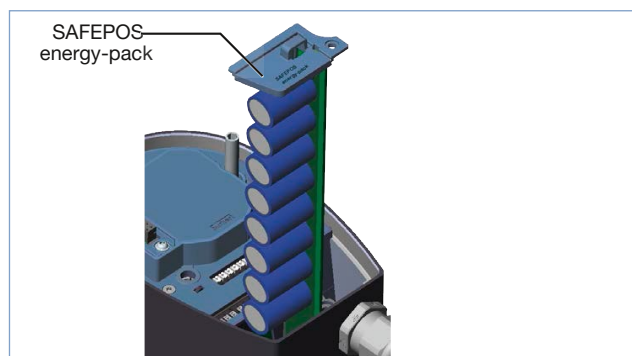
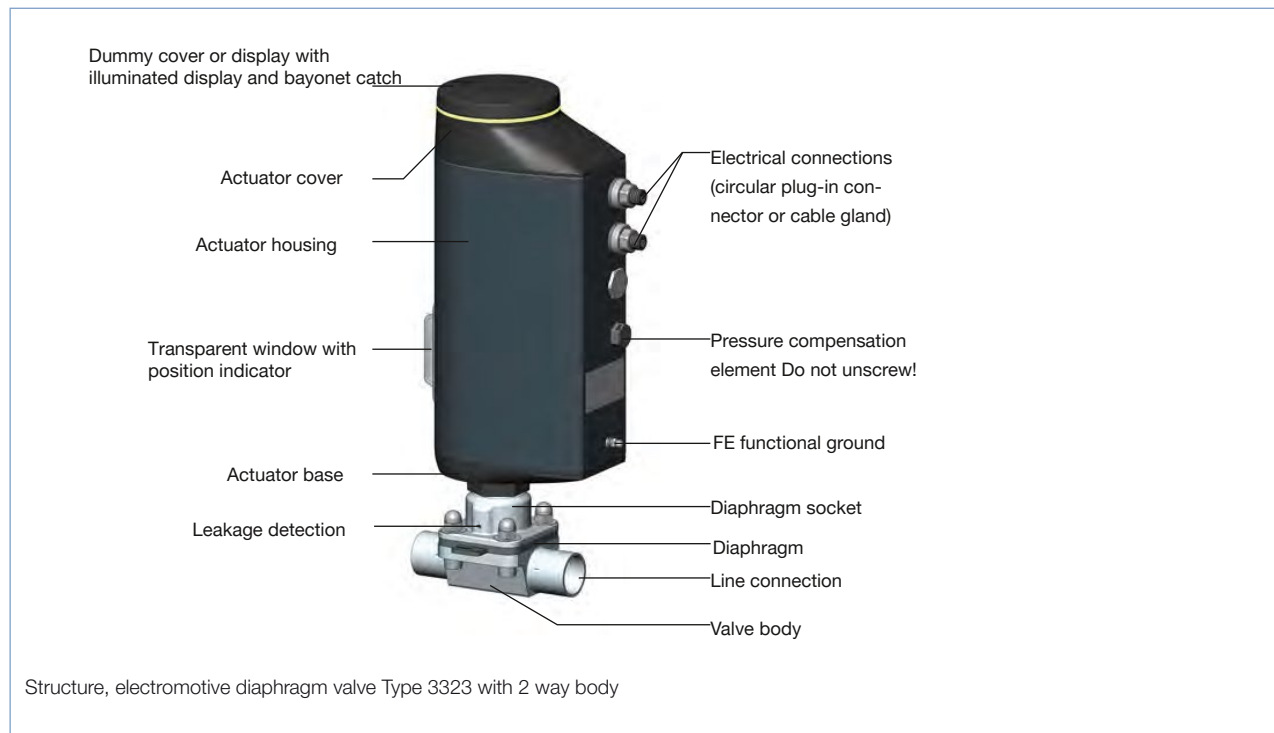

Safety position with energy storage (Option)

The safety positions in case of power interruption is realized by the optional energy-pack SAFEPOS. The desired position is adjusted in the menu. Here any intermediate position can be defined in addition to the end positions (NO / NC). The energy storage has a lifespan of up to 10 years, depending on the operating conditions. The power of the energy storage is monitored and a warning is displayed to indicate its life is coming to an end. The memory is designed as a plug-in module making it easy to exchange. Without energy storage the valve remains in the last position. The energy storage is fully charged after maximum 100 seconds (depending on the operating conditions) and ready to use.

Controls and indicators

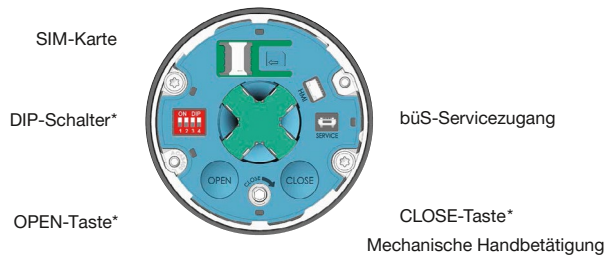

Devices without display module

In the version without control display the basic functions are operated by 4 DIP switches and 2 pushbuttons. These are located under the dummy cover which can be removed manual by turning. Through the büS service access, the device can also be configured in detail with the Bürkert communicator software. For this, the optional USB-büS interface kit is required.

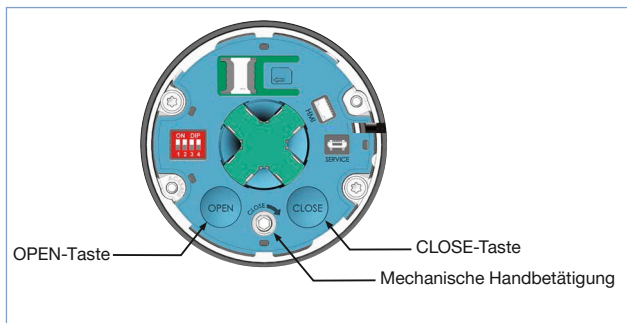

Manual and electrical operation

The manual override for mechanical operation of the valve is located under the dummy cover or the display module.

Electrical manual override for the procedure is carried out directly on the touch screen, or in the version without a display by two buttons below the dummy cover.

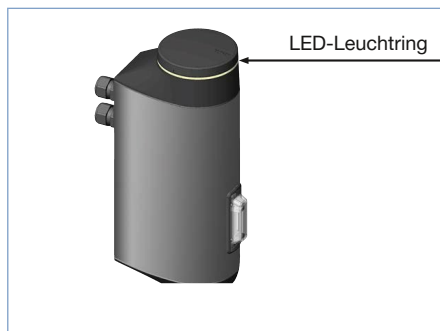

360° - LED illuminated ring

To display the device status, the valve end position and the operating condition, a visible 360° LED illuminated ring is mounted around the dummy cover or the display module. The LED ring lights up, flashes or flashes in one or different colors. Depending on customer requirements 4 different LED modes can be selected (Namur mode, valve mode without warnings, valve mode with warnings, LED off)

Controls and indicators, continued

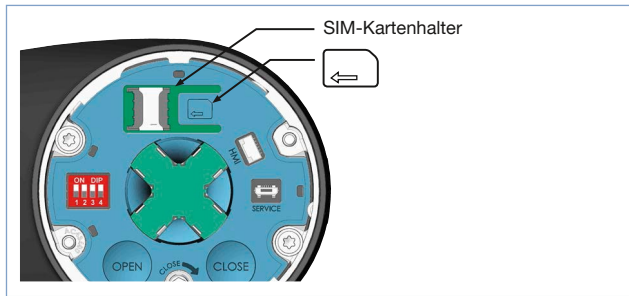
**SIM card as data storage (option)**

With the SIM card optional device-specific values and user settings can be saved and quickly transferred to another device.

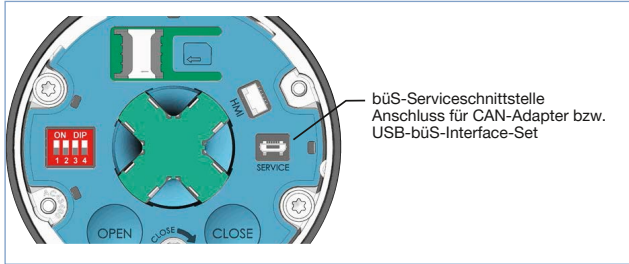
**bUS service interface**

The bUS service interface connects the device to the communicator software on a PC, laptop or smartphone. From there, a configuration of the device or failure diagnosis can be performed.

Materials

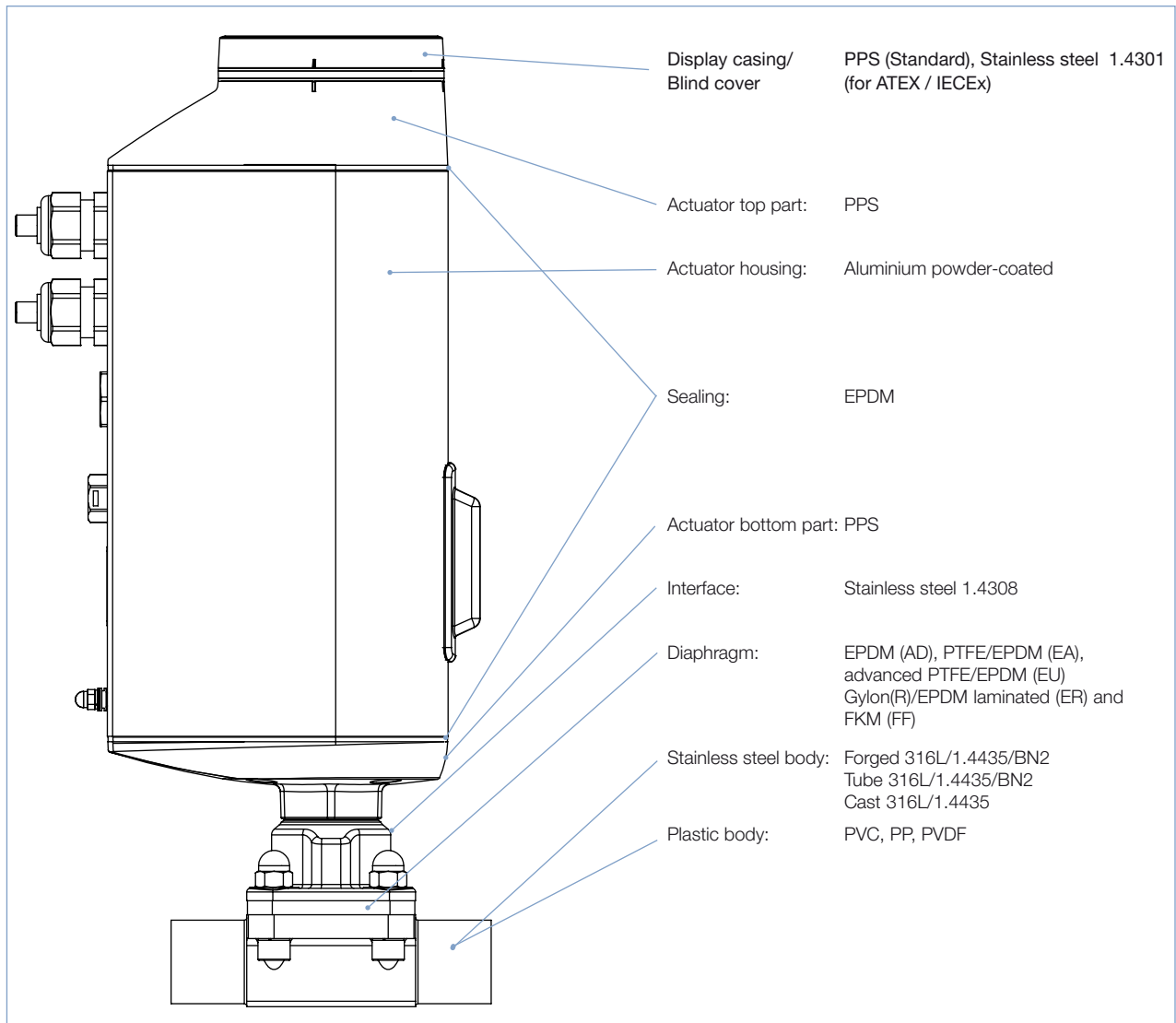

Note: The depiction of the products may differ from the actual specific design (e.g. body material, and port connection)

Approvals

Suitability for foodstuffs / sterile applications



- The composition of the EPDM (AD), PTFE/EPDM (EA), advanced PTFE/EPDM (EU) and GYLON®/EPDM laminated (ER) diaphragms corresponds to the Code of Federal Regulations, published by the FDA (Food and Drug Administration, USA).



- The composition of the EPDM (AD), PTFE/EPDM (EA), advanced PTFE/EPDM (EU) and GYLON®/EPDM laminated (ER) diaphragms is suitable for the application with food and beverage (acc. to EC-Regulation 1935/2004/EC)



- The composition of the EPDM (AD), PTFE/EPDM (EA), advanced PTFE/EPDM (EU) and GYLON®/EPDM laminated (ER) diaphragms are approved acc. USP Class VI

- The diaphragm valve with tube valve body and EPDM or PTFE has been evaluated for compliance with the *Hygienic Equipment Design Criteria* of the EHEDG

Technical data

Temperature chart

The maximum allowable ambient temperature and media temperature influence each other. The maximum allowable temperature curves of different device variants can be seen in the temperature chart.

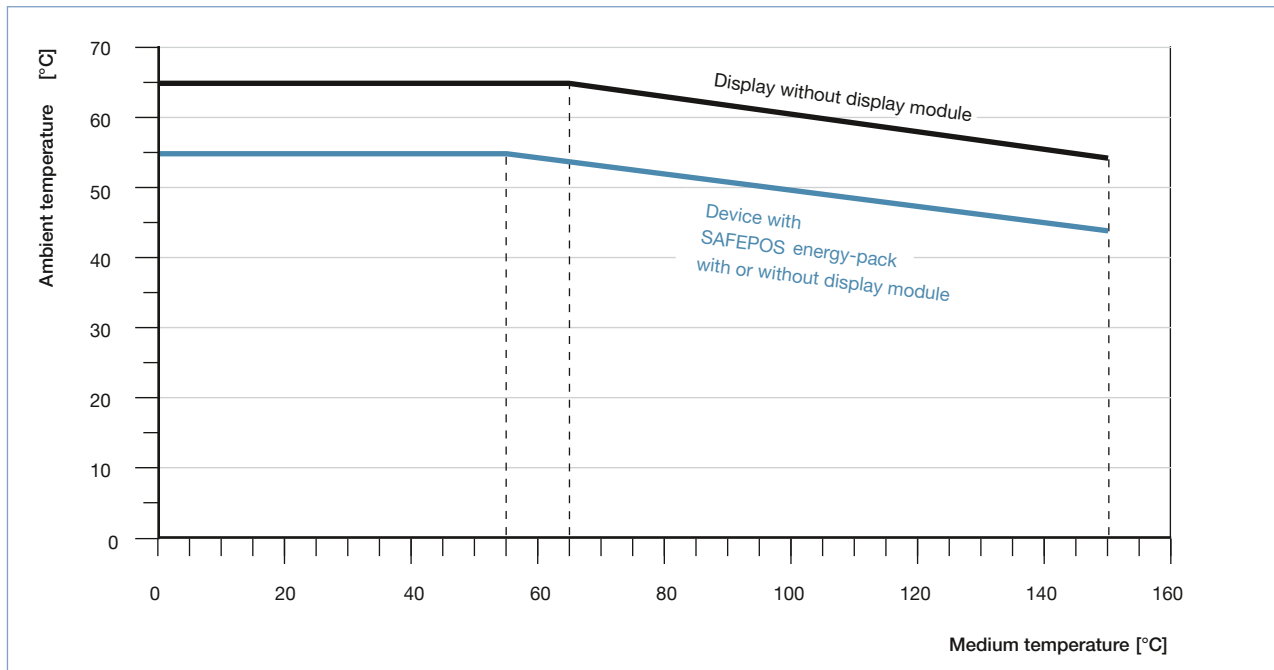

Pressure values

Diaphragm size	Max. operating pressure [bar]	
	EPDM, FKM	PTFE, advanced PTFE, Gylon®
8	10	10
15	10	10
20	10	10
25	10	10
32	8	5.5
40	4	2.5

Pressure values: K_v value water [m^3/h]: Measured at +20 °C, 1 bar pressure at valve inlet and free outlet.

Installation for self-draining operation

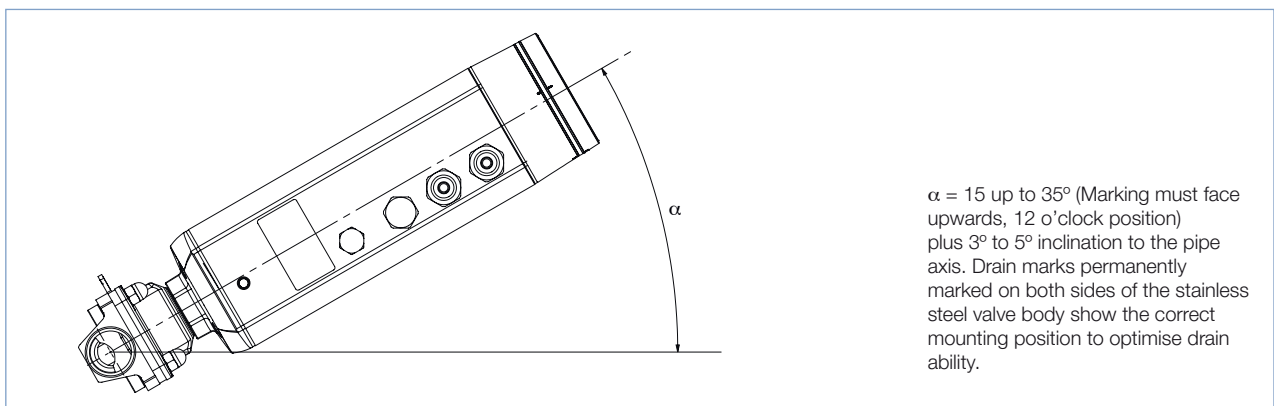

Technical data, continued

Electrical data	
Protection class	3 acc. to DIN EN 61140
Electrical connections	Cable gland, 2 x M20 or 2 circular plug-in connector M12, 5 pin and 8 pin
Operating voltage	24 V DC \pm 10 % max. residual ripple 10 %
Operating current [A]*	max. 3 A including actuator at max. load and charging current of the optional SAFEPOS energy-pack (charging current approx. 1 A)
Lifelong energy storage SAFEPOS energy-pack	up to 10 years (depending on operating conditions)
Electronic without actuator [W]*	min. 2 W, max. 4 W
Control	
Output digital:	current limit 100 mA
Input digital:	0...5 V = log "0", 10...30 V = log "1" inverted input reversed accordingly
Communication interface:	Connection to PC via USB bÜS interface set
Communication Software:	Bürkert communicator

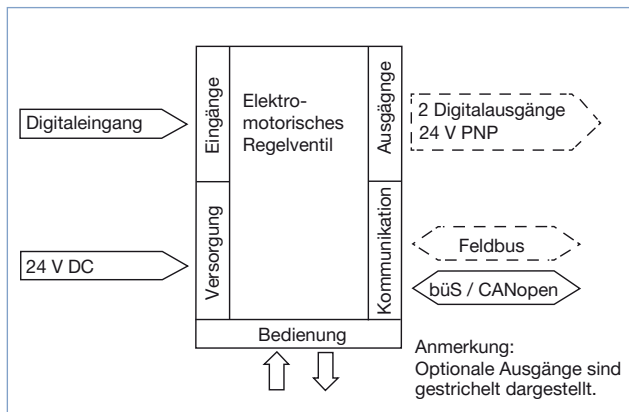
**Electrical control and interface**

The position of the actuator is regulated according to the position setpoint. The position setpoint value is specified either by an external standard signal (digital) or via a field bus (digital).

Digital Control

For digital control 2 variants are available for the inputs and outputs and the connection interface

Input and output:

* 1 digital input, 2 digital output

Interface:

* cable gland with connection terminal

* M12 circular connectors (optional)

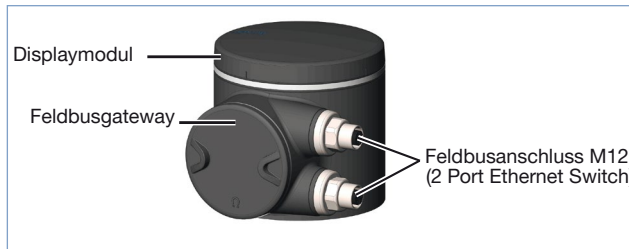
**Fieldbus: EtherNet/IP, PROFINET, Modbus TCP (option)**

The Fieldbus Gateway for EtherNet / IP, PROFINET and Modbus TCP is integrated into a special module. It has 2 fieldbus connections with 4 pin M12 circular connectors. Under the gateway housing cover are the interfaces for the fieldbus connection and status LEDs. If there is a need to be include it in a network then the configuration of the Ethernet can be performed via the web server.

Standard (mit Display oder Blinddeckel)

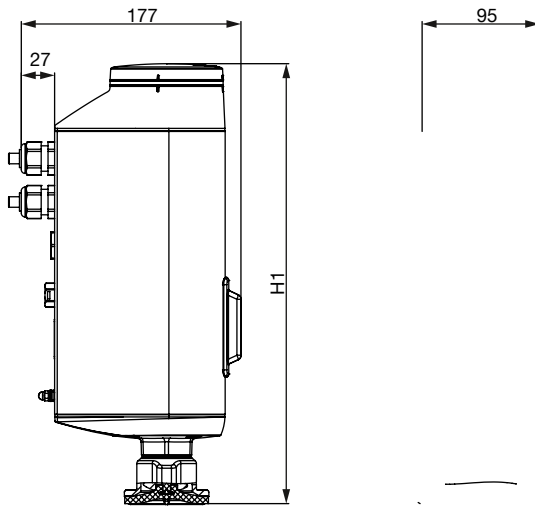

mit Feldbus Schnittstelle

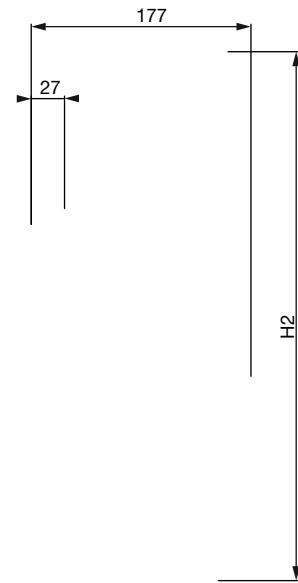

Diaphragm size	Height [mm]	
	H1	H2
8	342	414
15	345	418
20	350	422
25	355	426
32	365	436
40	370	442

Technical data, forged body

Body label

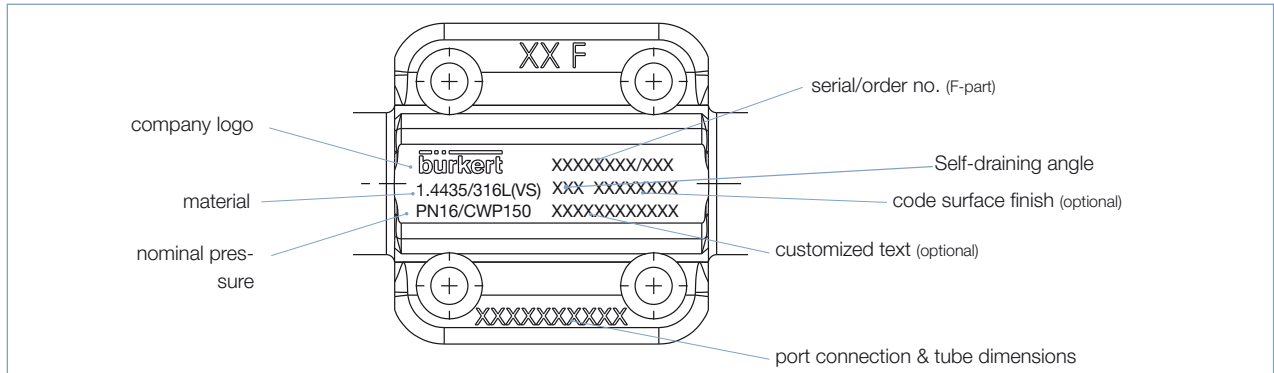

K_v values

Port Connection DN		Diaphragm size	K _v value [m³/h]					
[mm]	[inch]		DIN EN ISO 1127 ISO 4200 DIN 11866 B	DIN 11850 2 DIN 11866 A	ASME BPE DIN 11866 C	DIN 11850 0	BS4825	SMS3008
6	¼"	8	-	-	-	1.1	-	-
8	¼"	8	1.5	-	0.7	1.7	0.5	-
10	⅜"	8	1.5	1.5	1.6	-	1.4	-
15	½"	8	-	-	1.5	-	-	-
10	⅜"	15	5.5	3.5	-	-	-	-
15	½"	15	6.5	6.5	3.1	-	3.7	-
20	¾"	15	-	-	6.5	-	-	-
20	¾"	20	12.5	12.4	8.4	-	8.9	-
25	1"	25	18	20	15.5	-	15.5	16
32	1¼"	40	-	34	-	-	-	-
40	1½"	40	41	40	37	-	37	38

Flow rate: K_v value water [m³/h]: Measured at +20°C, 1 bar pressure at valve inlet and free outlet.

Dimensions [mm] forged body - weld end

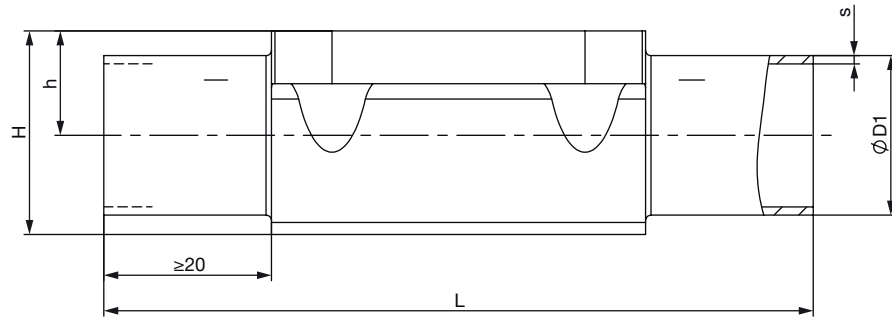

Port Connection DN		Diaphragm Size	ØD1	s	h	H	L
[mm]	[inch]		[mm]	[mm]	[mm]	[mm]	[mm]
DIN EN ISO 1127 / ISO 4200 / DIN 11866 B							
8	¼"	8	13.5	1.6	9	19	90
10	⅜"	8	17.2	1.6	9	19	90
10	⅜"	15	17.2	1.6	12	24	110
15	½"	15	21.3	1.6	12	24	110
20	¾"	20	26.9	1.6	16	30	119
25	1"	25	33.7	2.0	19	37	129
32	1¼"	40	42.4	2.0	28	52	161
40	1½"	40	48.3	2.0	28	52	161
DIN 11850 2 / DIN 11866 A							
10	⅜"	8	13.0	1.5	9	19	90
10	⅜"	15	13.0	1.5	8	20	110
15	½"	15	19.0	1.5	12	24	110
20	¾"	20	23.0	1.5	16	30	119
25	1"	25	29.0	1.5	19	37	129
32	1¼"	40	35.0	1.5	28	52	161
40	1½"	40	41.0	1.5	28	52	161
ASME BPE / DIN 11866 C							
8	¼"	8	6.35	0.89	6	15	78
10	⅜"	8	9.53	0.89	6	15	89
15	½"	8	12.70	1.65	9	19	89
15	½"	15	12.70	1.65	8	20	108
20	¾"	15	19.05	1.65	12	24	108
20	¾"	20	19.05	1.65	16	30	117
25	1"	25	25.40	1.65	19	37	127
40	1½"	40	38.10	1.65	28	52	159
BS 4825							
8	¼"	8	6.35	1.20	6	15	78
10	⅜"	8	9.53	1.20	6	15	89
15	½"	15	12.70	1.20	8	20	108
20	¾"	20	19.05	1.20	16	30	117
25	1"	25	25.40	1.65	19	37	127
40	1½"	40	38.10	1.65	28	52	159
SMS 3008							
25	1"	25	25.0	1.2	19	37	129
40	1½"	40	38.0	1.2	28	52	161
DIN 11850 0							
6	⅛"	8	8.0	1.0	6	15	90
8	¼"	8	10.0	1.0	6	15	90

Dimensions [mm] forged body - clamp

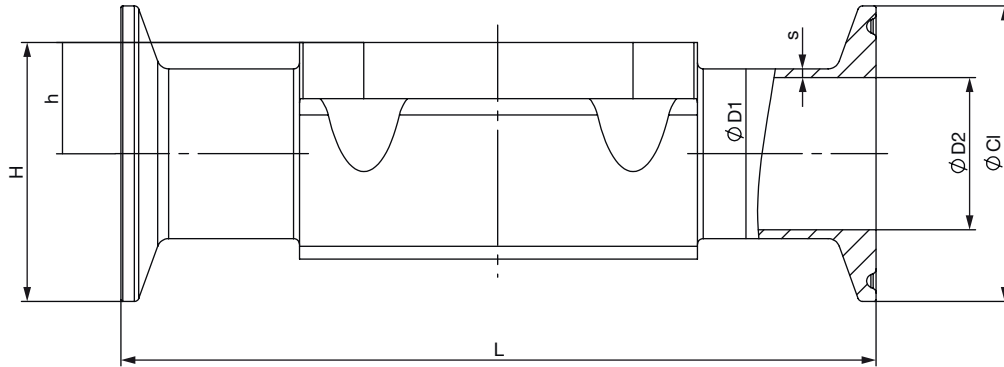

Port Connection DN		Diaphragm Size	ØD1	s	CI	ØD2	h	H	L
[mm]	[inch]								
DIN 32676 B with pipe EN ISO 4200									
15	½"	15	21.3	1.6	50.5	18.1	12	37	167
20	¾"	20	26.9	1.6	50.5	23.7	16	41	114
25	1"	25	33.7	2.0	50.5	29.7	19	44	129
40	1½"	40	48.3	2.0	64.0	44.3	28	60	161
DIN 32676 A with pipe DIN 11850 2									
10	⅜"	15	13.0	1.5	34.0	10.0	8	25	110
15	½"	15	19.0	1.5	34.0	16.0	12	29	110
20	¾"	20	23.0	1.5	34.0	20.0	16	33	119
25	1"	25	29.0	1.5	50.5	26.0	19	44	129
40	1½"	40	41.0	1.5	50.5	38.0	28	53	161
ASME BPE									
8	¼"	8	6.35	0.89	25.0	4.57	6	18	64
10	⅜"	8	9.53	0.89	25.0	7.75	6	18	89
15	½"	8	12.70	1.65	25.0	9.4	9	22	89
15	½"	15	12.70	1.65	25.0	9.4	8	21	89
20	¾"	20	19.05	1.65	25.0	15.75	16	29	102
25	1"	25	25.40	1.65	50.5	22.1	19	44	114
40	1½"	40	38.10	1.65	50.5	34.8	28	53	140

Technical data, tube body

Body label

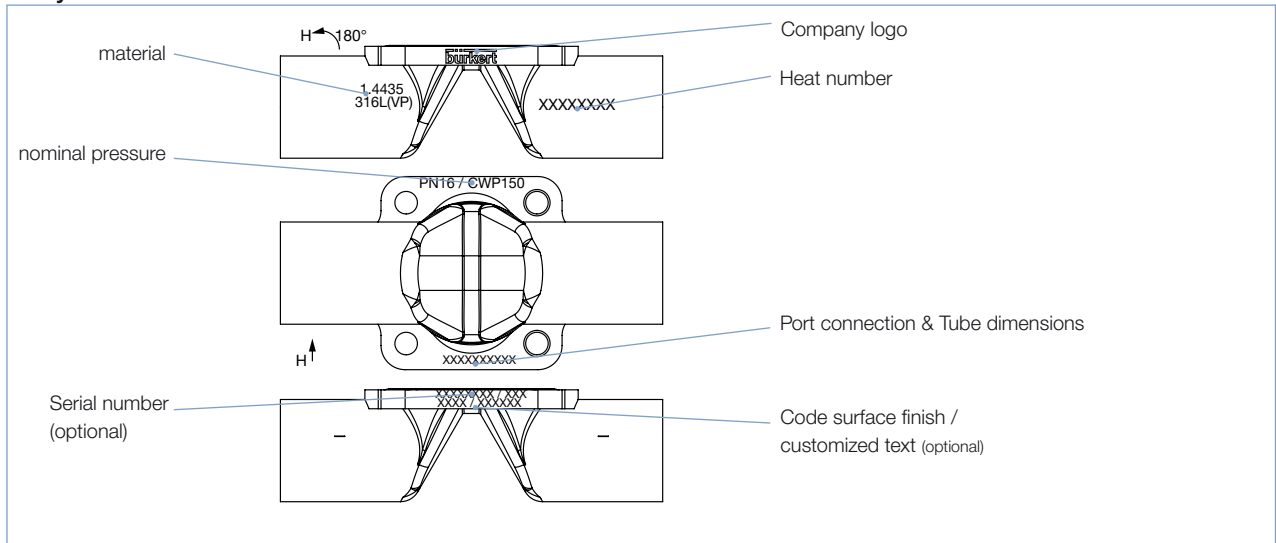

K_v values

Port Connection DN		Diaphragm size	K _v value [m³/h]		
[mm]	[inch]		DIN EN ISO 1127 ISO 4200 DIN 11866 B	DIN 11850 2 DIN 11866 A	ASME BPE DIN 11866 C
8	¼"	8	2.1		-
10	⅜"	8		2.1	
15	½"	8	-		2
		15	6.7	6.5	-
20	¾"	15	-	6.5	6.5
		20	13		-
25	1"	20	-	14	12.5
		25	17.5		-
32	1¼"	25		20	-
		32	36		-
40	1½"	32	-	35	30
		40	47	-	-
50	2"	40	-	44	40

Flow rate: K_v value water [m³/h]: Measured at +20 °C, 1 bar pressure at valve inlet and free outlet.

Dimensions [mm] tube body - weld end

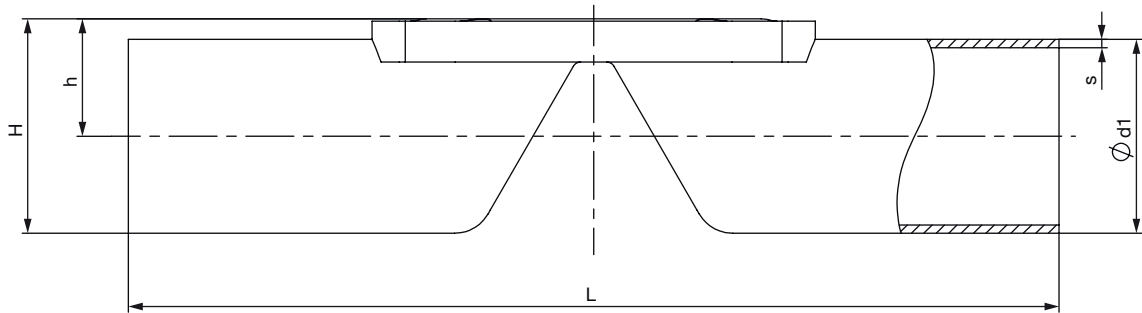

Port Connection DN		Diaphragm Size	ØD1	s	h	H	L
[inch]	[mm]						
ASME BPE / DIN 11866 RC							
1/2"	15	8	12.7	1.65	9.5	15.8	90
3/4"	20	15	19.05	1.65	13.2	22.8	117
1"	25	20	25.4	1.65	16.4	29.1	127
1 1/2"	40	32	38.1	1.65	23.0	42.0	159
2"	50	40	50.8	1.65	30.6	56.0	190
DIN EN ISO 1127 / ISO 4200 / DIN 11866 RB							
1/4"	8	8	13.5	1.6	9.9	16.6	90
1/2"	15	15	21.3	1.6	14.4	25.0	110
3/4"	20	20	26.6	1.6	17.2	30.5	119
1"	25	25	33.7	2.0	20.6	37.4	129
1 1/4"	32	32	42.4	2.0	25.1	46.3	148
1 1/2"	40	40	48.3	2.0	29.4	53.5	161
DIN 11850 2 / DIN 11866 A							
3/8"	10	8	13	1.5	9.9	16.4	90
1/2"	15	15	19	1.5	13.2	22.7	110
3/4"	20	15	23	1.5	15.2	26.7	119
1"	25	20	29	1.5	18.2	32.7	129
1 1/4"	32	25	35	1.5	21.2	38.7	148
1 1/2"	40	32	41	1.5	24.4	44.9	161
2"	50	40	53	1.5	31.7	58.2	192

Technical data - plastic body

Pressure-temperature chart

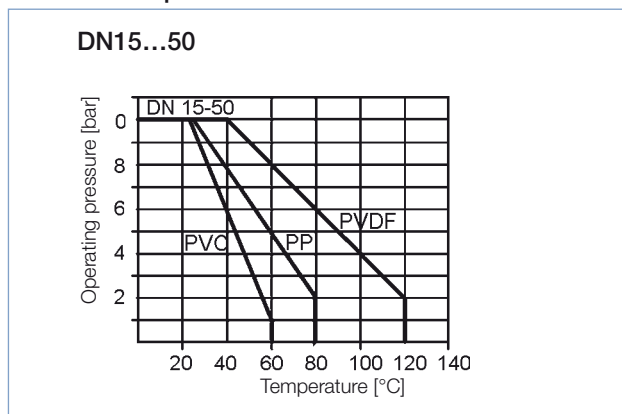

K_v values

Port Connection DN		Diaphragm size	K _v value [m ³ /h]
[mm]	[inch]		
15	½"	15	3.5
20	¾"	20	7
25	1"	25	11
32	1¼"	32	18
40	1½"	40	26

Flow rate: K_v value water [m³/h]: Measured at +20 °C, 1 bar pressure at valve inlet and free outlet.

Dimensions [mm] plastic body - weld end and solvent socket

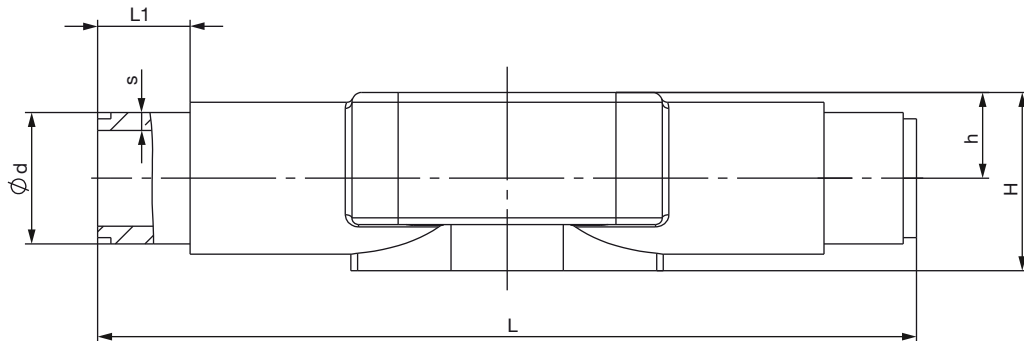





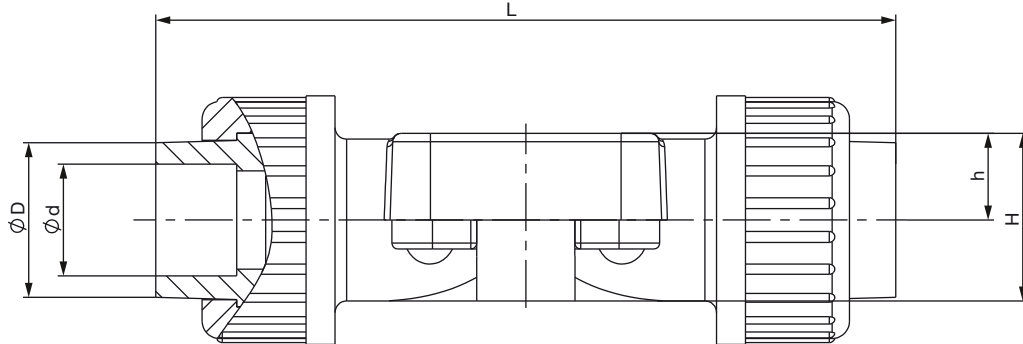





PVC - solvent socket								
Port Connection DN		Diaphragm Size	Ød [mm]	s [mm]	h [mm]	H [mm]	L [mm]	L1 [mm]
[inch]	[mm]							
½"	15	15	20	2.75	15	29	124	16
¾"	20	20	25	3.0	18.5	36	144	19
1"	25	25	32	3.75	22	43	154	22
1¼"	32	32	40	4.5	27	52.5	174	26
1½"	40	40	50	6.0	33	65.5	194	31
PVDF - weld end								
Port Connection DN		Diaphragm Size	Ød [mm]	s [mm]	h [mm]	H [mm]	L [mm]	L1 [mm]
[inch]	[mm]							
½"	15	15	20	2.35	15	29	124	19
¾"	20	20	25	2.55	18.5	36	144	21
1"	25	25	32	3.2	22	43	154	23
1¼"	32	32	40	3.9	27	52.5	174	25
1½"	40	40	50	5.2	33	65.5	194	28
PP - weld end								
Port Connection DN		Diaphragm Size	Ød [mm]	s [mm]	h [mm]	H [mm]	L [mm]	L1 [mm]
[inch]	[mm]							
½"	15	15	20	2.7	15	29	124	14
¾"	20	20	25	2.95	18.5	36	144	16
1"	25	25	32	3.7	22	43	154	18
1¼"	32	32	40	4.45	27	52.5	174	20
1½"	40	40	50	5.95	33	65.5	194	23

Dimensions [mm] plastic body - true union



PVC true union (solvent)							
Port Connection DN		Diaphragm Size	Ød	ØD	h	H	L
[inch]	[mm]						
½"	15	15	20	27	15	29	128
¾"	20	20	25	33	18.5	36	152
1"	25	25	32	41	22	43	166
1¼"	32	32	40	48	27	52.5	192
1½"	40	40	50	59	33	65.5	222
PVDF true union (weld)							
Port Connection DN		Diaphragm Size	Ød	ØD	h	H	L
[inch]	[mm]						
½"	15	15	20	28	15	29	128
¾"	20	20	25	36	18.5	36	150
1"	25	25	32	42	22	43	162
1¼"	32	32	40	53	27	52.5	184
1½"	40	40	50	59	33	65.5	210
PP true union (weld)							
Port Connection DN		Diaphragm Size	Ød	ØD	h	H	L
[inch]	[mm]						
½"	15	15	20	27	15	29	128
¾"	20	20	25	36	18.5	36	150
1"	25	25	32	41	22	43	162
1¼"	32	32	40	53	27	52.5	184
1½"	40	40	50	59	33	65.5	210

Ordering Chart for accessories

Accessories	Article no.
Connection cable:	
Connection cable with M12 socket, 4 pin, (length 5 m) for operating voltage	918038 
Connection cable with M12 socket, 8 pin, (length 2 m) for input and output signals	919061 
USB-büS interface set:	
büS stick set 1 (including power supply unit, bus-stick, terminating resistor, Y-distributor, 0.7 m cable with M12 connector)	772426 
büS stick set 2 (including bus-stick, terminating resistor, Y-distributor, 0.7 m cable with M12 connector)	772551 
büS adapter for büS interface set (M12 on büS service interface Micro-USB)	773254 
büS cable extensions from M12 plug to M12 socket:	
Connecting cable, length 1 m	772404 
Connecting cable, length 3 m	772405 
Connecting cable, length 5 m	772406 
Connecting cable, length 10 m	772407 
Miscellaneous	
Bürkert Communicator	Infos at www.burkert.com
SIM card	291773 
Bracket for line connection DN08 to DN40 (Note: Diaphragm size 08 includes the bracket in delivery)	697473 

Valve system – request for quotation

Note

You can fill out the fields directly in the PDF file before printing out the form.

▶ Please fill out and send to your nearest Bürkert office* with your inquiry or order

Company:	Contact person:
Customer no.:	Department:
Address:	Tel./Fax.:
Postcode/town:	E-Mail:

= mandatory fields to fill out

Quantity:

Required delivery date:

Operating data

Pipe line	DN <input type="text"/>	PN <input type="text"/>
Pipe Material	<input type="text"/>	
<input checked="" type="checkbox"/> Process medium	<input type="text"/>	
<input checked="" type="checkbox"/> Type of medium	<input type="checkbox"/> Liquid	<input type="checkbox"/> Steam <input type="checkbox"/> Gas

Valves features

Body material	<input type="checkbox"/> Forged stainless steel	<input type="checkbox"/> Stainless steel tube	<input type="checkbox"/> PVC	<input type="checkbox"/> PP	<input type="checkbox"/> PVDF
Inner surface	<input type="checkbox"/> Electropolished Ra ≤ 0.38 µm (ASME BPE SF4)	<input type="checkbox"/> Mech. polished Ra ≤ 0.5 µm (ASME BPE SF1)	<input type="checkbox"/> Not relevant		
Port connection size	<input type="text"/> please state required size				
Port connections	Stainless steel				
Weld ends	<input type="checkbox"/> ASME BPE/DIN DIN 11866 C	Clamp		<input type="checkbox"/> ASME BPE	
	<input type="checkbox"/> DIN EN ISO 1127/ISO 4200/DIN11866 B			<input type="checkbox"/> DIN 32676 A (with pipe DIN 11850 2)	
	<input type="checkbox"/> DIN 11850 2/DIN11866 A			<input type="checkbox"/> DIN 32676 B (with pipe ISO 4200)	
	<input type="checkbox"/> BS4825				
	<input type="checkbox"/> SMS 3008				
	<input type="checkbox"/> DIN 11850 0				
Plastic	<input type="checkbox"/> True union (solvent)	<input type="checkbox"/> weld ends			
	<input type="checkbox"/> true union (weld)	<input type="checkbox"/> solvent sockets			
Diaphragm size	<input type="text"/> please state required size				
Diaphragm material	<input type="checkbox"/> EPDM (AD)	<input type="checkbox"/> PTFE/EPDM (EA)	<input type="checkbox"/> advanced PTFE/EPDM (EU)		
	<input type="checkbox"/> Gylon@/EPDM laminated (ER)	<input type="checkbox"/> FKM (FF)			
Approvals	<input type="checkbox"/> FDA	<input type="checkbox"/> EC-Regulation 1935/2004/EC	<input type="checkbox"/> USP Class VI	<input type="checkbox"/> EHEDG	

Valve system – request for quotation, continued

Control unit features

Communication

- | | |
|---------------------------------------|--------------------------------------|
| <input type="checkbox"/> Binary | <input type="checkbox"/> Digital |
| <input type="checkbox"/> 1 binary IN | <input type="checkbox"/> Ethernet/IP |
| <input type="checkbox"/> 1 binary OUT | <input type="checkbox"/> Profinet |
| | <input type="checkbox"/> Modbus TCP |

Electrical connection

- | | |
|---|------------------------------------|
| <input type="checkbox"/> Cable gland (without Fieldbus) | <input type="checkbox"/> Multipole |
|---|------------------------------------|

SIM card

- with
 without

Approval and Conformity (optional)

- ATEX II Cat 3G/D / IECEx
 cULus Cert. No. 238179

Accessories

- Mounting bracket (for diaphragm size 8 included in delivery)
 Bürkert communicator - for more information visit www.burkert.com

Certifications

- Test Report 2.2 acc. to EN 10204 (Article no. 803722)
 Inspection Certificate 3.1 acc. to EN 10204 - Material Test Report (included in delivery)
 Inspection Certificate 3.1 acc. to EN 10204 - Surface Roughness Measurement (Article no. 804175)
 FDA and USP compliance

Please specify Article no. (if known):

Comments

To find your nearest Bürkert office, click on the orange box →

www.burkert.comIn case of special application conditions,
please consult for advice.Subject to alteration.
© Christian Bürkert GmbH & Co. KG

1802/8_EU-en_00895323