



# Technical Data Sheet Type 24



2/2-way solenoid valve  
 NC - Valve normally closed (as standard)  
 NO - Valve normally open (as option)

Force-pilot operated piston design valve. No differential pressure is necessary for operation. In standard (NC) the valve closes with spring power.

■ Solenoid valve for gaseous and liquid media

Type 24

## TECHNICAL SPECIFICATIONS

Type of control	Force pilot operated no pressure difference required
Design	Piston design
Connection	Flanges DN65 - DN300 EN 1092-1 Form B1/B2 Other flange connections like ASME on request
Installation	With actuator upright
Pressure	0 - 40 bar (see table on page 2)
Medium	Clean, neutral, gaseous and liquid media
max. viscosity	22 mm <sup>2</sup> /s
Temperature range	Medium: -30 °C up to +80 °C Ambient: -30 °C up to +50 °C In consideration of the restrictions described on page 4
Body material	Spheroidal graphite iron EN-GJS-400-18-LT Cast iron EN-GJL-250 Cast steel GP240 GH Stainless steel 1.4581
Metallic inner parts	Brass and Stainless steel
Sealing	NBR, FKM, EPDM, PTFE
Supply voltage	AC~ 24V, 110V, 230V DC= 12V, 24V Other supply voltages on request
Voltage tolerance	-10% / +10%
Power consumption	.242 = 46 Watt    .248 = 30 Watt ⚡ .272 = 100 Watt    .278 = 47 Watt ⚡ .352 = 150 Watt    .358 = 75 Watt ⚡ .402 = 250 Watt
Protection class	IP65 acc. to DIN 60529
Duty factor	100% ED-VDE 0580
Connection type	Terminal box
Ex-proof	acc. to 2014/34/EU (ATEX) Further Ex-proof on request

## VALVE FEATURES

- No pressure difference required
- High life time
- Simple compact valve design
- Reliable and sturdy sealing elements
- Long-term availability of spare parts

## FUNCTION

NC – non energized closed      NO – non-energized open

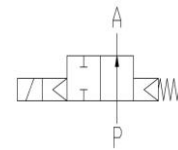
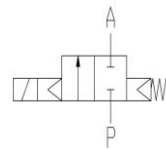

## CERTIFICATES



## ORDERING SYSTEM

Type	Conn.	Housing	Seal	Coil	Option
. 2 4 0 7 /	0 4 0 1 /	. 2 4 2 -	H A		
07 DN65 08 DN80 09 DN100 10 DN125 11 DN150 12 DN200 13 DN250 14 DN300	03 EN-GJS-400-18-LT 04 EN-GJL-250 05 GP240 GH 08 St.steel 1.4408	01 NBR 02 FKM 04 PTFE 06 EPDM	2 Standard IP65 8 Explosion proof acc. to directive 2014/34/EU (ATEX)		

# TECHNICAL FEATURES

DN	Kv-value m³/h	Standard type	max. pressure for coils				max. pressure for coils ATEX		
			.242	.272	.352.	.402	.248	.278	.358
65	75,0	.2407/..01/	0-16	0-40	0-40	-	0-4	0-16	0-40
80	97,0	.2408/..01/	0-16	0-25	0-40	-	0-2	0-16	0-40
100	143,0	.2409/..01/	-	0-25	0-40	-	-	0-16	0-40
125	240,0	.2410/..01/	-	0-16	0-40	-	-	0-5	0-25
150	370,0	.2411/..01/	-	0-8	0-16	0-40	-	-	0-10
200	625,0	.2412/..01/	-	-	0-8	0-40	-	-	0-4
250	950,0	.2413/..01/	-	-	-	0-16	-	-	-
300	1400,0	.2414/..01/	-	-	-	0-16	-	-	-

The flow rate mentioned in the table applies to the strongest coil.  
Max. pressure 16 bar with EN-GJL-250 body PN16

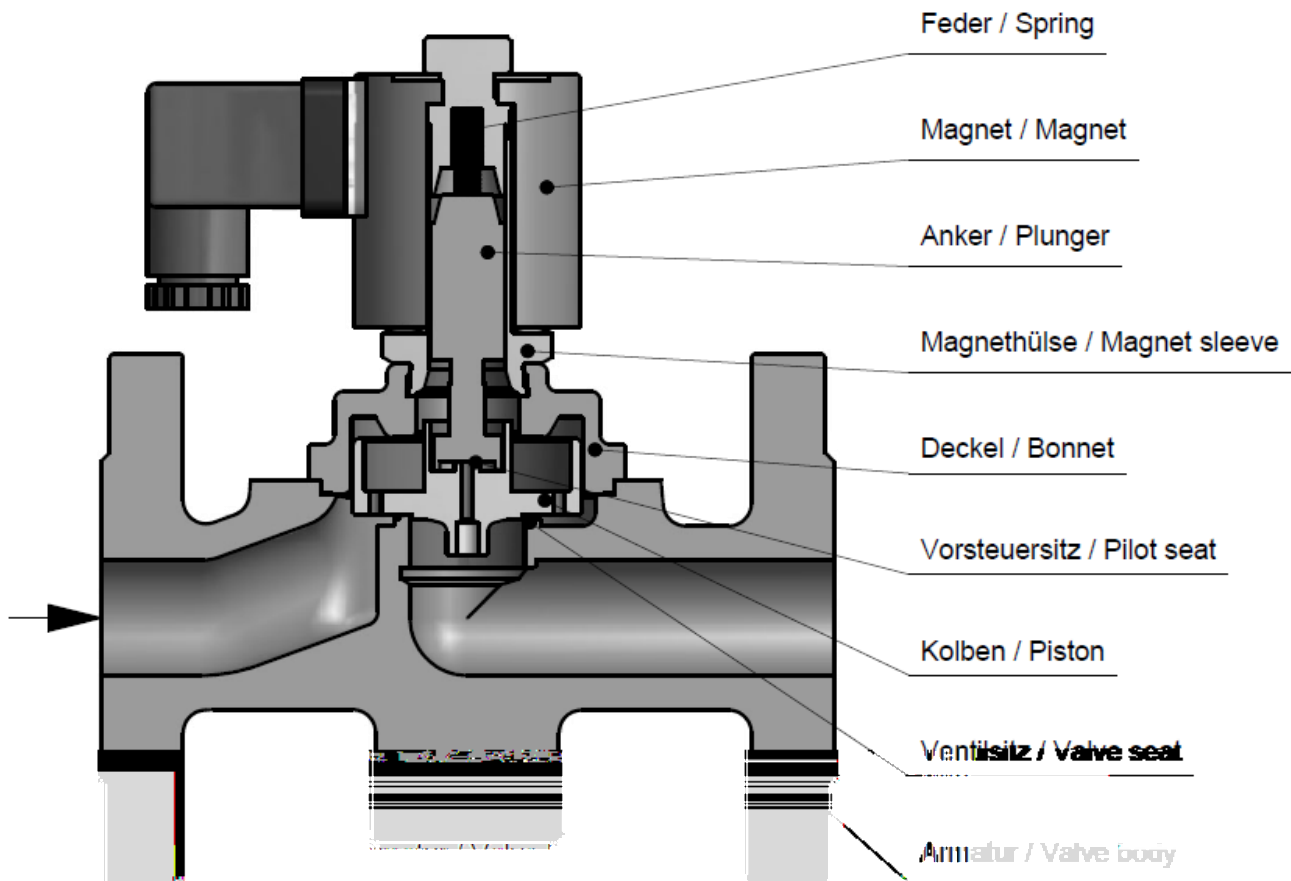

# DIMENSIONS

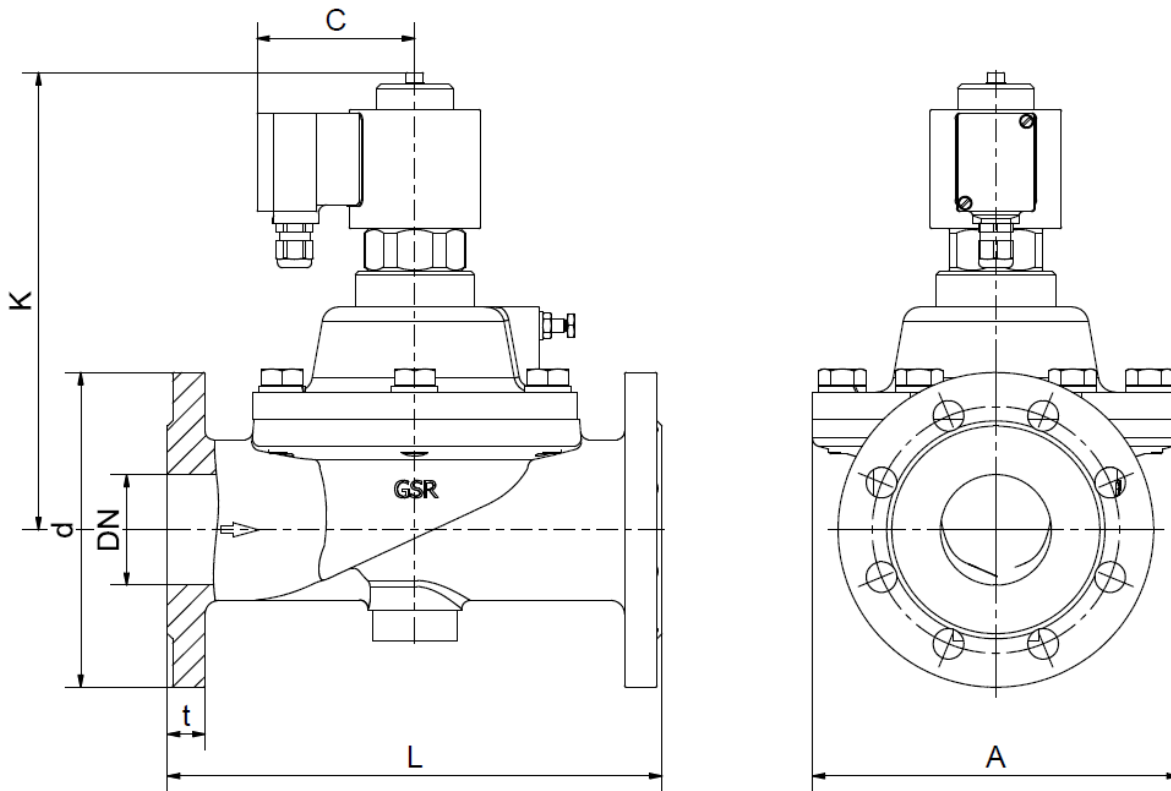

Type 24

Coil	.242/.248		.272/.278				
Type	.2407	.2408	.2407	.2408	.2409	.2410	.2411
DN	65	80	65	80	100	125	150
A	215	245	215	245	270	235	265
C	93	93	107	107	107	107	107
d	185	200	185	200	235	270	285
K	270	275	295	295	320	330	360
L	290	310	290	310	350	400	480
t	22	24	22	24	24	26	28
kg	27,0	35,0	30,5	38,5	61,0	59,0	70,5

Coil	.352/.358						.402			
Type	.2407	.2408	.2409	.2410	.2411	.2412	.2411	.2412	.2413	.2414
DN	65	80	100	125	150	200	150	200	250	300
A	215	245	270	235	265	345	265	345	415	500
C	127	127	127	127	127	127	158	158	158	158
d	185	200	235	270	285	340	285	340	405	460
K	380	390	380	390	450	485	615	on req.	on req.	on req.
L	290	310	350	400	480	600	480	600	730	850
t	22	24	24	26	28	34	28	34	38	42
kg	43,0	50,0	61,0	70,0	91,0	145,0	140,0	on req.	on req.	on req.

## INFORMATION

- It is imperative to observe the installation and safety instructions in our operating and service manuals.
- For information on our GSR ordering code, please refer to our catalogs. If you have any questions, we will be glad to assist you.
- Required ordering information: valve type, function NC/NO, pressure range, connection, nominal width, medium, flow rate, medium and ambient temperatures, connection voltage.
- **Detailed production-specific drawings and other technical information will be made available when an order is placed**

## PLEASE NOTE

Each individual application decides which valve type is required, the main factor being the resistance of the materials to the operating medium. The correct selection of materials requires knowledge of the concentration, temperature and degree of contamination of the medium. Other criteria include the operating pressure and max. volumetric flow, since, in addition to high temperatures, high pressures and high flow rates must also be taken into account when selecting the materials.

**All materials used for our valves, be it housing, seals or magnets, will be carefully selected in view of the different application areas. Any information given is non-binding and serves for orientation only. No claims under warranty can be derived therefrom.**

## Heating and power of solenoid coils

The GSR default solenoid valves are designed for continuous operation (100% ED = power-on time) under normal operating conditions. The pulling force of a solenoid coil is basically influenced by three elements:

- The self-heating of the magnetic coil
- The medium temperature
- The ambient temperature

GSR solenoid coils are by default designed for a maximum ambient temperature of +35 °C. This specification applies for the maximum allowable operating pressure specified in the data sheet of the corresponding valve, 100% duty cycle and a medium temperature of +80 °C.

A higher ambient temperature is possible, when lower values are applied for the other influencing parameters. When the max. operation pressure and max. ambient temperature of +50 °C is given the medium temperature is not allowed to be higher than max. +50 °C. In addition to that, deviations from the default design temperature range are possible, e.g. when temperature coils or other constructive measures are used. Please contact the GSR headquarters to discuss the specific application.

More precise specifications and technical data with regard to the operating conditions can be found in the data sheets of the solenoid coils and the solenoid valve regarded. Please observe that the surface temperature of a permanently loaded coil can amount up to +120 °C, solely by the self-heating of the coil. The power consumption of our default solenoid valves was calculated to DIN VDE 05820 for a coil temperature of +20 °C.

- The GSR logo is a registered trademark of GSR Ventiltechnik GmbH & Co. KG.
- Note: All texts and images are the property of GSR Ventiltechnik GmbH & Co. KG and must not be replicated or modified, not even in part, without written approval.
- Original products may differ from the product images shown, due to different materials and the like.
- Subject to error and changes.

**Stand: 08.17, MK-MG, Version 1.**