

## HEAT EXCHANGERS AIR/OIL TYPE LAC

# Heat exchangers Air/Oil LAC

- LAC with AC Motor for Industrial Use
- Maximum cooling capacity 300 kW

# Heat exchangers Air/Oil LAC-X

- ATEX Version. Approved for applications where there may be an explosive environment above ground.

# Heat exchangers Air/Oil LAC-M

- Adapted to be able better to deal with corrosion attacks, for example in marine environments.

Clever design and the right choice of materials and components produce a long useful life, high availability and low service and maintenance costs.

Easy to maintain and easy to retrofit in many applications.

Compact design and low weight.



Quiet fan and fan motor.

AC motor single-phase for smaller and three-phase for larger cooler sizes.

Cooler matrix with low pressure drop and high cooling capacity.

# HEAT EXCHANGERS AIR/OIL TYPE LAC



The cooling capacity curves are based on the inlet oil temperature and the ambient air temperature. An oil temperature of 60 °C and an air temperature of 20 °C produce a temperature difference of 40 °C. Multiply by kW/°C for total cooling capacity.

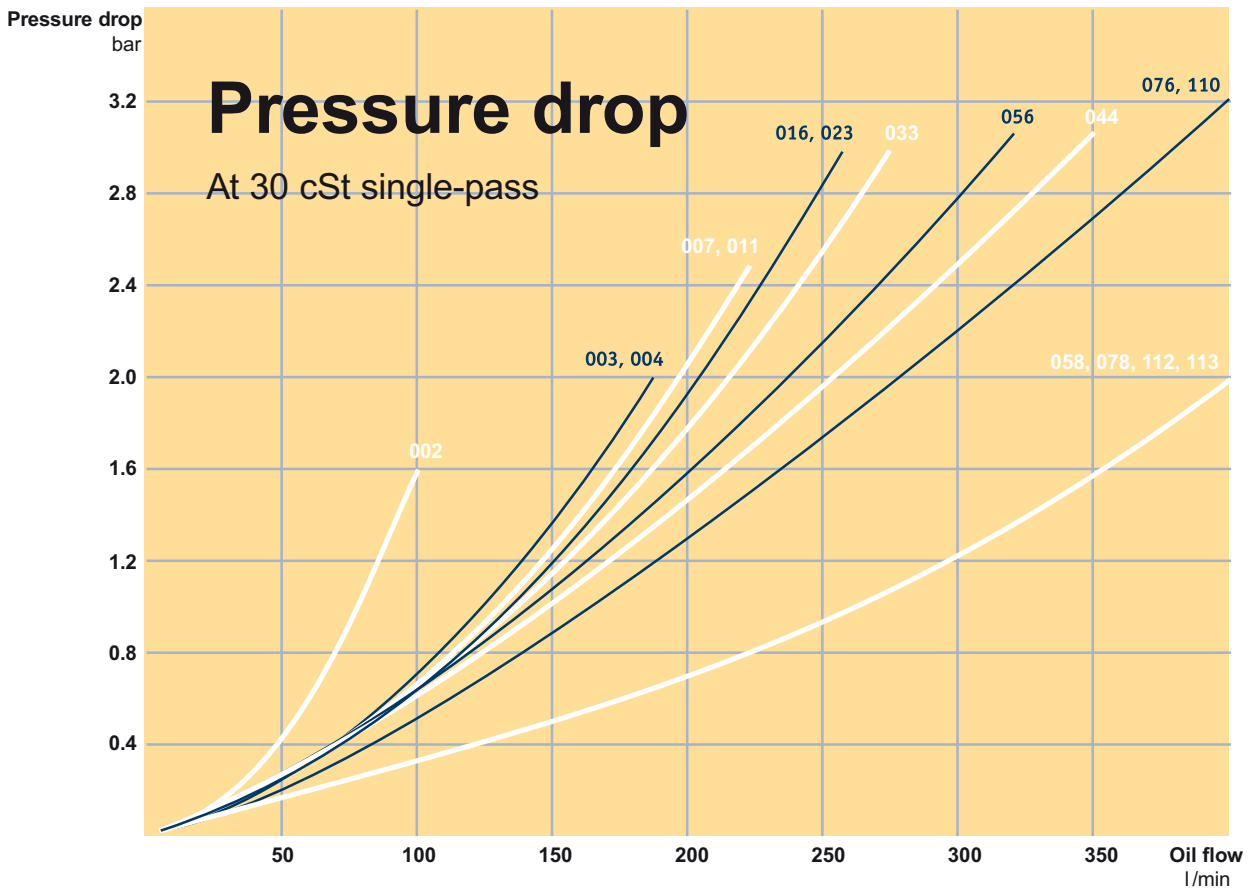

# HEAT EXCHANGERS AIR/OIL TYPE LAC

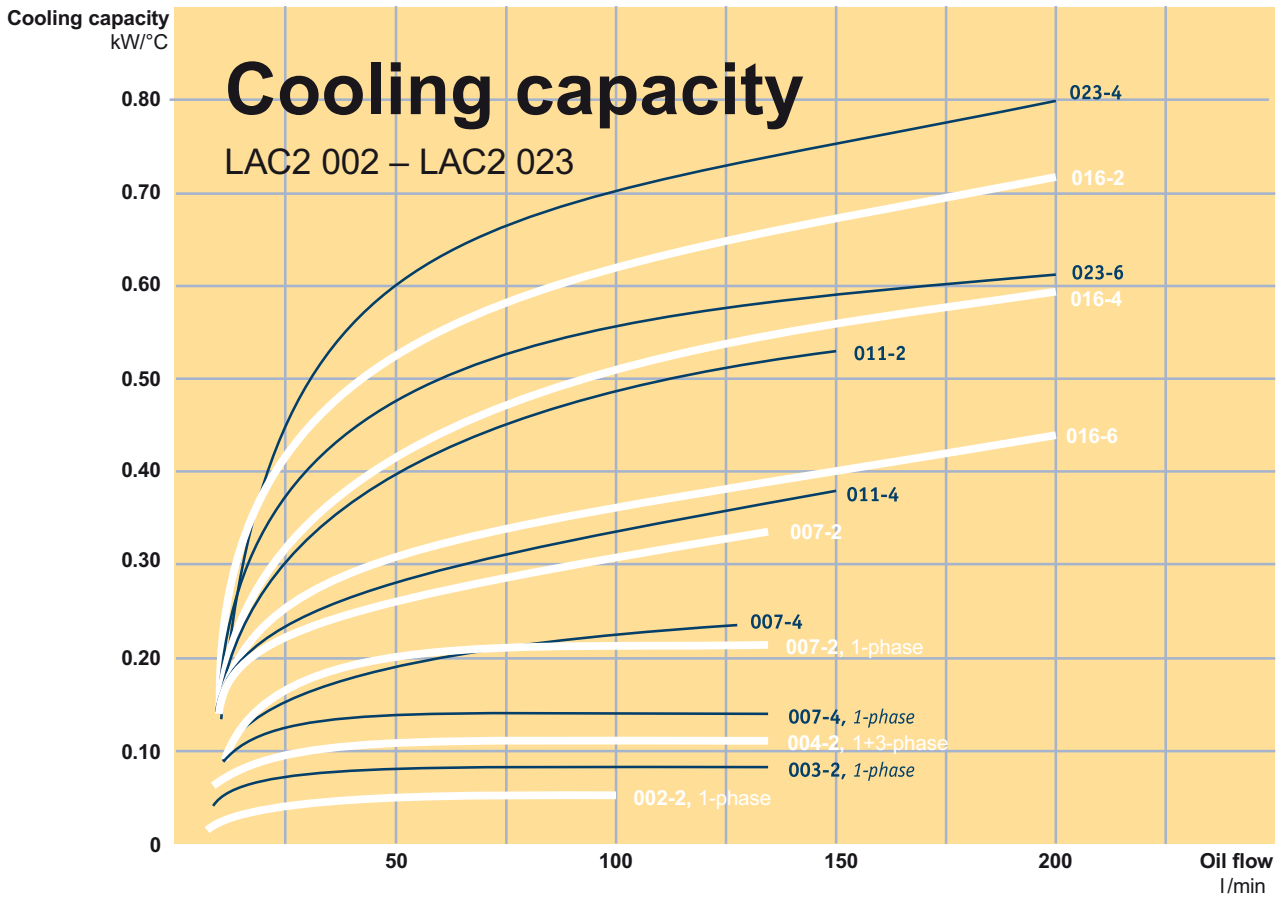
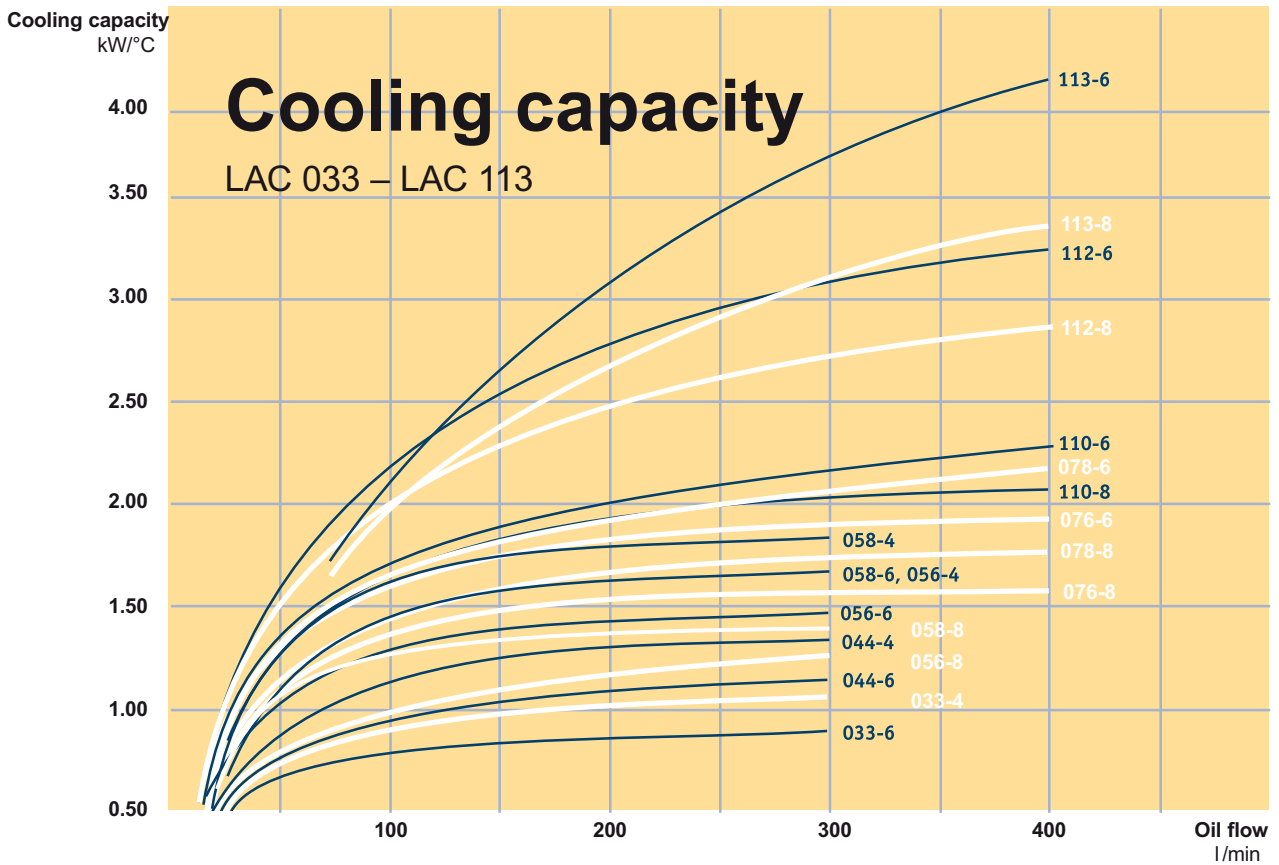

Cooling capacity tolerance  $\pm 10\%$  kW.

# HEAT EXCHANGERS AIR/OIL TYPE LAC

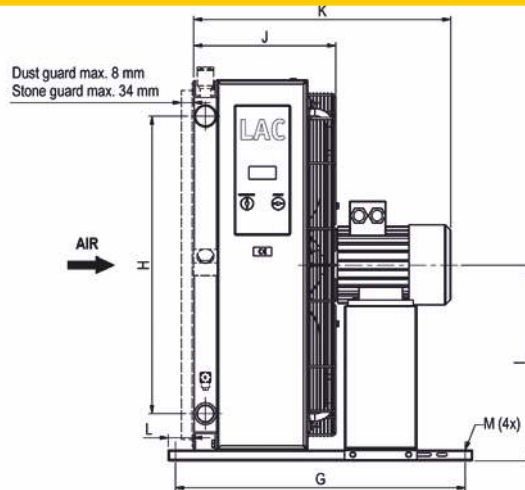

TYPE	Acoustic pressure level LpA dB(A) 1m*	No. of poles/ Capacity kw	Weight Kg (approx)
LAC2 002-2-single-phase	50	2-0.05	4
LAC2 003-2-single-phase	61	2-0.05	5
LAC2 004-2-single-phase	63	2-0.07	6
LAC2 004-2-single-phase	63	2-0.07	6
LAC2 007-4-single-phase	65	2-0.08	9
LAC2 007-2-single-phase	79	2-0.24	10
LAC2 007-4-three-phase	62	4-0.25	15
LAC2 007-2-three-phase	79	2-0.55	16
LAC2 011-4-three-phase	67	4-0.25	20
LAC2 011-2-three-phase	82	2-1.10	25
LAC2 016-6-three-phase	60	6-0.18	23
LAC2 016-4-three-phase	70	4-0.37	24
LAC2 016-2-three-phase	86	2-1.10	27
LAC2 023-6-three-phase	64	6-0.18	35
LAC2 023-4-three-phase	76	4-0.75	36
LAC 033-6-three-phase	74	6-0.55	45
LAC 033-4-three-phase	84	4-2.20	52
LAC 044-6-three-phase	76	6-0.55	63
LAC 044-4-three-phase	85	4-2.20	65
LAC 056-8-three-phase	73	8-0.55	73
LAC 056-6-three-phase	81	6-1.50	75
LAC 056-4-three-phase	84	4-2.20	75
LAC 058-8-three-phase	74	8-0.55	80
LAC 058-6-three-phase	82	6-1.50	82
LAC 058-4-three-phase	85	4-2.20	82
LAC 076-8-three-phase	79	8-1.10	130
LAC 076-6-three-phase	86	6-2.20	140
LAC 078-8-three-phase	80	8-1.10	136
LAC 078-6-three-phase	87	6-2.20	146
LAC 110-8-three-phase	84	8-2.20	160
LAC 110-6-three-phase	90	6-5.50	170
LAC 112-8-three-phase	85	8-2.20	168
LAC 112-6-three-phase	91	6-5.50	178
LAC 113-8-three-phase	80	8-2.20	218
LAC 113-6-three-phase	88	6-5.50	237
LAC 200-8-three-phase	86	8-4.00	365
LAC 200-6-three-phase	92	6-11.00	405

\* = Noise level tolerance  $\pm 3$  dB(A).

# HEAT EXCHANGERS AIR/OIL TYPE LAC

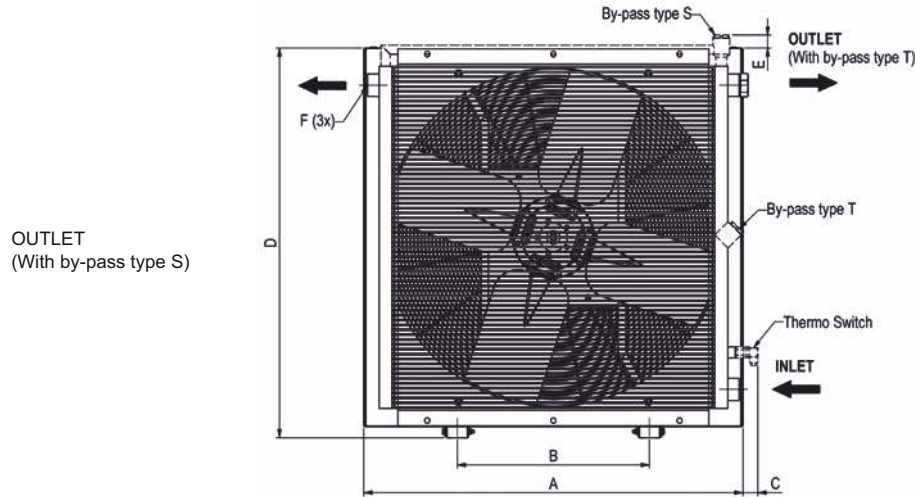

TYPE	A	B	C	D	E	F	G	I	J	K	L	Mø	
LAC2 002-2-single-phase	165	74	82	189	-	G $\frac{1}{2}$	190	72	97	105	167	39	9
LAC2 003-2-single-phase	244	134	82	223	71	G1	148	90	114	161	218	31	9x14
LAC2 004-4-single-phase	267	134	82	256	69	G1	148	90	131	165	222	28	9x14
LAC2 004-2-single-phase	267	134	82	256	69	G1	148	90	131	165	222	28	9x14
LAC2 007-4-single-phase	340	203	77	345	54	G1	267	160	175	189	249	49	9x14
LAC2 007-2-single-phase	340	203	77	345	54	G1	267	160	175	189	249	49	9x14
LAC2 007-4-three-phase	365	203	64	395	42	G1	510	160	213	225	429	50	9
LAC2 007-2-three-phase	365	203	64	395	42	G1	510	160	213	225	434	50	9
LAC2 011-4-three-phase	440	203	62	470	41	G1	510	230	250	249	453	50	9
LAC2 011-2-three-phase	440	203	62	470	41	G1	510	230	250	249	475	50	9
LAC2 016-6-three-phase	496	203	66	526	46	G1	510	230	278	272	474	50	9
LAC2 016-4-three-phase	496	203	66	526	46	G1	510	230	278	272	479	50	9
LAC2 016-2-three-phase	496	203	66	526	46	G1	510	230	278	272	496	50	9
LAC2 023-6-three-phase	580	356	63	610	44	G1	510	305	320	287	489	50	9
LAC2 023-4-three-phase	580	356	63	610	44	G1	510	305	320	287	511	50	9
LAC 033-6-three-phase	692	356	53	722	42	G $\frac{1}{4}$	510	406	376	318	534	50	9
LAC 033-4-three-phase	692	356	53	722	42	G $\frac{1}{4}$	510	406	376	318	618	50	9
LAC 044-6-three-phase	692	356	53	866	59	G $\frac{1}{4}$	510	584	448	343	559	50	9
LAC 044-4-three-phase	692	356	53	866	59	G $\frac{1}{4}$	510	584	448	343	643	50	9
LAC 056-8-three-phase	868	356	49	898	43	G $\frac{1}{4}$	510	584	448	343	643	50	9
LAC 056-6-three-phase	868	508	49	898	43	G $\frac{1}{4}$	510	584	464	368	668	50	9
LAC 056-4-three-phase	868	508	49	898	43	G $\frac{1}{4}$	510	584	464	368	668	50	9
LAC 058-8-three-phase	868	508	49	898	43	G2	510	584	464	388	652	30	9
LAC 058-6-three-phase	868	508	49	898	43	G2	510	584	464	388	682	30	9
LAC 058-4-three-phase	868	508	49	898	43	G2	510	584	464	388	688	30	9
LAC 076-8-three-phase	1022	518	41	1052	45	G $\frac{1}{2}$	800	821	541	393	693	70	14
LAC 076-6-three-phase	1022	518	41	1052	45	G $\frac{1}{2}$	800	821	541	393	710	70	14
LAC 078-8-three-phase	1022	518	41	1052	45	G2	800	821	541	413	713	50	14
LAC 078-6-three-phase	1022	518	41	1052	45	G2	800	821	541	413	730	50	14
LAC 110-8-three-phase	1185	600	54	1215	45	G2	800	985	623	418	785	70	14
LAC 110-6-three-phase	1185	600	54	1215	45	G2	800	985	623	418	785	70	14
LAC 112-8-three-phase	1185	600	54	1215	45	G2	800	985	623	438	805	50	14
LAC 112-6-three-phase	1185	600	54	1215	45	G2	800	985	623	438	805	50	14
LAC 113-8-three-phase	1200	600	82	1215	45	G2	860	985	623	465	833	82	14
LAC 113-6-three-phase	1200	600	82	1215	45	G2	860	985	623	465	871	82	14
LAC 200-8-three-phase	Please see LAC 200 brochure for more information												
LAC 200-6-three-phase	Please see LAC 200 brochure for more information												

## Key for LAC/LAC2 Air Oil Coolers

All positions must be filled in when ordering:

EXAMPLE: LAC2 - 016 - 6 - A - 50 - T20 - D - 0  
 1 2 3 4 5 6 7 8

### 1. AIR OIL COOLER WITH AC MOTOR = LAC / LAC2

#### 2. COOLER SIZE

002, 003, 004, 007, 011, 016, 023, 033, 044, 056, 058, 076, 078, 110, 112, 113 and 200.

#### 3. NUMBER OF POLES, MOTOR

2 - pole = 2  
 4 - pole = 4  
 6 - pole = 6  
 8 - pole = 8

#### 4. VOLTAGE AND FREQUENCY (Ie2 GURANTEED @50HZ)

No motor = 0  
 230/400V 50Hz<sup>1)</sup> = A  
 460V alt 480V 60Hz<sup>1)</sup> = B  
 Single-phase 230V 50Hz (not IE2) = C  
 230/400V 50Hz 460 alt 480V 60Hz<sup>2)</sup> = D  
 500V 50Hz (not standard) = E  
 400/690V 50Hz 460 alt 480V 60Hz = F  
 525V 50Hz, 575V 60Hz = G  
 Motor for special voltage or frequency (stated in plain language<sup>3)</sup>) = X

1) for LAC 033 to LAC 113  
 2) For LAC2 007 to LAC2 023  
 3) For other options contact Parker for assistance. All motors apply to IEC 60034, IEC 60072 and EN 50347

#### 5. THERMO CONTACT

No thermo contact = 00  
 40 °C = 40  
 50 °C = 50  
 60 °C = 60  
 70 °C = 70  
 80 °C = 80  
 90 °C = 90

#### 6. COOLER MATRIX

Standard = 000  
 Two-pass = T00  
**Built-in, pressure-controlled bypass, single-pass**  
 2 bar = S20  
 5 bar = S50  
 8 bar = S80

#### Built-in, pressure-controlled bypass, two-pass

2 bar = T20  
 5 bar = T50  
 8 bar = T80

#### Built-in, temperature and pressure-controlled bypass, single-pass

50 °C, 2.2 bar = S25  
 60 °C, 2.2 bar = S26  
 70 °C, 2.2 bar = S27  
 90 °C, 2.2 bar = S29

#### Built-in, temperature and pressure-controlled bypass two-pass\*

50 °C, 2.2 bar = T25  
 60 °C, 2.2 bar = T26  
 70 °C, 2.2 bar = T27  
 90 °C, 2.2 bar = T29

\* = not for LAC2 002 - LAC2 004

#### 7. MATRIX GUARD

No guard = 0  
 Stone guard = S  
 Dust guard = D  
 Dust and stone guard = P

#### 8. STANDARD/SPECIAL

Standard = O  
 Special = Z

#### TECHNICAL SPECIFICATION

##### FLUID COMBINATION

Mineral oil HL/HLP in accordance with DIN 51524  
 Oil/water emulsion HFA, HFB in accordance with CETOP RP 77H  
 Water glycol HFC in accordance with CETOP RP 77H  
 Phosphate ester HFD-R in accordance with CETOP RP 77H

##### MATERIAL

Cooler matrix Aluminum  
 Fan blades/hub Glass fibre reinforced polypropylene/ Aluminum

Fan housing	Steel
Fan guard	Steel
Other parts	Steel
Surface treatment	Electrostatically powder-coated

#### TECHNICAL DATA, COOLER MATRIX

Maximum static operating pressure	21 bar
Dynamic operating pressure	14 bar*
Heat transfer limit	± 6 %
Maximum oil inlet temperature	120 °C

\* Tested in accordance with ISO/DIS 10771-1

#### TECHNICAL DATA FOR 3-PHASE MOTOR

3-phase asynchronous motors in accordance with IEC 34-1 and IEC 72 in accordance with DIN 57530/VDE 0530  
 Insulation class F  
 Rise of temperature B  
 Protection class IP 55

#### TECHNICAL DATA FOR 1-PHASE MOTOR

Insulation class	B
Rise of temperature	B
Protection class	IP 44

#### TECHNICAL DATA FOR 3-PHASE MOTOR LAC2 004

Rated voltage	230/400V 50/60Hz
Insulation class	B
Rise of temperature	B
Protection class	IP 44

#### COOLING CAPACITY CURVE

The cooling capacity curves in this technical data sheet are based on tests in accordance with EN 1048 and have been produced using oil type ISO VG 46 at 60 °C.

#### CONTACT US FOR ADVICE ON

Oil temperatures > 120 °C  
 Oil viscosity > 100 cSt  
 Aggressive environments  
 Ambient air rich in particles  
 High-altitude locations

The information in this brochure is subject to change without prior notice.

## Take the Next Step

- choose the right accessories

Supplementing a hydraulic system with a cooler, cooler accessories and an accumulator gives you increased availability and a longer useful life, as well

as lower service and repair costs. All applications and operating environments are unique. A well-planned choice of the following accessories can thus further

improve your hydraulic system. Please contact us for guidance.

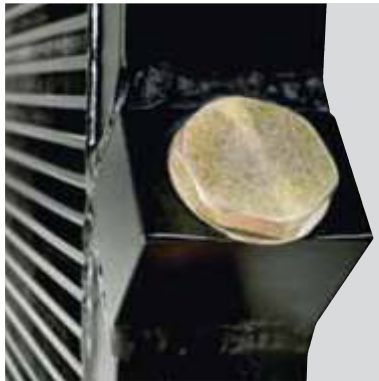

### **Pressure-controlled bypass valve**Integrated

Allows the oil to bypass the cooler matrix if the pressure drop is too high. Reduces the risk of the cooler bursting, e.g. in connection with cold starts and temporary peaks in pressure or flow. Available for single-pass or two-pass matrix design.



### **Thermo contact**

Sensor with fixed set point, for temperature warnings. Can be used for more cost-efficient operation and better environmental consideration through the automatic control of the fan motor, either on or off.



### **Temperature-controlled bypass valve**Integrated

Allows the oil to bypass the cooler matrix if the pressure drop is higher than 2,2 bar or less than the chosen temperature. The bypass closes when the oil temperature increases. Different closing temperatures available. Available for singlepass or two-pass matrix design



### **Lifting eyes**

For simple installation and relocation.



### **Temperature-controlled 3-way valve**External

Same function as the temperature-controlled bypass valve, but positioned externally.

*Note: must be ordered separately.*



### **Stone guard/Dust guard**

Protects components and systems from tough conditions.